

Service Manual



TSG601 Serial Digital Generator 070-8911-03

This document applies to firmware version 1.00 and above.

Warning

The servicing instructions are for use by qualified personnel only. To avoid personal injury, do not perform any servicing unless you are qualified to do so. Refer to all safety summaries prior to performing service.

www.tektronix.com

Copyright © Tektronix. All rights reserved. Licensed software products are owned by Tektronix or its subsidiaries or suppliers, and are protected by national copyright laws and international treaty provisions.

Tektronix products are covered by U.S. and foreign patents, issued and pending. Information in this publication supercedes that in all previously published material. Specifications and price change privileges reserved.

TEKTRONIX and TEK are registered trademarks of Tektronix, Inc.

Contacting Tektronix

Tektronix, Inc.
14200 SW Karl Braun Drive
P.O. Box 500
Beaverton, OR 97077
USA

For product information, sales, service, and technical support:

- In North America, call 1-800-833-9200.
- Worldwide, visit www.tektronix.com to find contacts in your area.

Warranty 2

Tektronix warrants that this product will be free from defects in materials and workmanship for a period of one (1) year from the date of shipment. If any such product proves defective during this warranty period, Tektronix, at its option, either will repair the defective product without charge for parts and labor, or will provide a replacement in exchange for the defective product. Parts, modules and replacement products used by Tektronix for warranty work may be new or reconditioned to like new performance. All replaced parts, modules and products become the property of Tektronix.

In order to obtain service under this warranty, Customer must notify Tektronix of the defect before the expiration of the warranty period and make suitable arrangements for the performance of service. Customer shall be responsible for packaging and shipping the defective product to the service center designated by Tektronix, with shipping charges prepaid. Tektronix shall pay for the return of the product to Customer if the shipment is to a location within the country in which the Tektronix service center is located. Customer shall be responsible for paying all shipping charges, duties, taxes, and any other charges for products returned to any other locations.

This warranty shall not apply to any defect, failure or damage caused by improper use or improper or inadequate maintenance and care. Tektronix shall not be obligated to furnish service under this warranty a) to repair damage resulting from attempts by personnel other than Tektronix representatives to install, repair or service the product; b) to repair damage resulting from improper use or connection to incompatible equipment; c) to repair any damage or malfunction caused by the use of non-Tektronix supplies; or d) to service a product that has been modified or integrated with other products when the effect of such modification or integration increases the time or difficulty of servicing the product.

THIS WARRANTY IS GIVEN BY TEKTRONIX WITH RESPECT TO THE PRODUCT IN LIEU OF ANY OTHER WARRANTIES, EXPRESS OR IMPLIED. TEKTRONIX AND ITS VENDORS DISCLAIM ANY IMPLIED WARRANTIES OF MERCHANTABILITY OR FITNESS FOR A PARTICULAR PURPOSE. TEKTRONIX' RESPONSIBILITY TO REPAIR OR REPLACE DEFECTIVE PRODUCTS IS THE SOLE AND EXCLUSIVE REMEDY PROVIDED TO THE CUSTOMER FOR BREACH OF THIS WARRANTY. TEKTRONIX AND ITS VENDORS WILL NOT BE LIABLE FOR ANY INDIRECT, SPECIAL, INCIDENTAL, OR CONSEQUENTIAL DAMAGES IRRESPECTIVE OF WHETHER TEKTRONIX OR THE VENDOR HAS ADVANCE NOTICE OF THE POSSIBILITY OF SUCH DAMAGES.

Table of Contents

General Safety Summary	v
Service Safety Summary	vii
Specifications	1-1
Introduction	1-1
Reference Documentation	1-1
Performance Conditions	1-2
Safety Standard Compliance	1-2
EMI Compliance	1-2
Specification Tables	1-3
Certifications and Compliances	1-12
Waveform Diagrams	1-13
Operating Information	2-1
Powering the Instrument	2-1
Keypad and Display Conventions	2-2
Using your TSG 601	2-3
Outputting Serial Video Test Signals	2-4
Adjusting the Output Amplitude	2-5
Controlling the Video Component (Y, Cr, Cb) Channels	2-5
Specifying 8- or 10-bit Data Words	2-6
Specifying CRC Content of the Signal	2-6
Inserting ID Messages	2-7
Editing ID Messages	2-7
Positioning ID Messages	2-7
Setting up an ID Cycle	2-8
Cable Simulation	2-9
Detecting Incorrect Termination	2-9
Saving (Storing) Presets and IDs	2-9
Recalling Presets and IDs	2-10
Theory of Operation	3-1
Block Diagram Description	3-1
Overview	3-1
Keypad	3-4
RS-232 Port	3-4
Microprocessor	3-4
Startup Sequence	3-5
Operating Sequence	3-6
Watchdog	3-6
Serializer	3-6
Return-Loss Detector	3-6
LCD Display	3-7
Power Supply	3-7
50 m Cable Simulator	3-7
Performance Verification and Adjustment Procedures	4-1
Required Test Equipment	4-1

Performance Verification Checklist	4-2
Performance Verification Procedures	4-2
Preparation	4-2
Procedures	4-3
Adjustment Procedures	4-6
Maintenance	5-1
Battery Hints	5-1
The BATTERY LOW Message	5-1
Low Battery Shut Down	5-1
Preventive Maintenance	5-2
Cleaning	5-2
Static-Sensitive Components	5-2
Troubleshooting Aids	5-3
Foldout Pages	5-3
Diagrams	5-3
Circuit Board Illustrations	5-4
Numbering	5-4
Diagnostics	5-4
The Diagnostic Menu	5-4
Corrective Maintenance	5-6
Obtaining Replacement Parts	5-6
Torque Specifications	5-7
Replacing Assemblies	5-7
Back Cover Removal/Replacement	5-7
Connector Panel Removal/Replacement	5-7
Main Board and LCD Removal/Replacement	5-8
Keypad Removal	5-8
Keypad Replacement	5-8
Replaceable Electrical Parts	6-1
Diagrams	7-1
Replaceable Mechanical Parts	8-1

List of Figures

Figure 1-1: Analog/Digital Line Timing, 625/50 Systems	1-5
Figure 1-2: Analog/Digital Line Timing, 525/60 Systems	1-5
Figure 1-3: Analog/Digital Field Timing, 625-line Systems	1-6
Figure 1-4: Analog/Digital Field Timing, 525-line Systems	1-7
Figure 1-5: 75% Color Bars, Y	1-13
Figure 1-6: 75% Color Bars, B-Y	1-14
Figure 1-7: 75% Color Bars, R-Y	1-14
Figure 1-8: 100% Color Bars, Y	1-15
Figure 1-9: 100% Color Bars, B-Y	1-15

Figure 1-10: 100% Color Bars, R-Y	1-16
Figure 1-11: Pluge 1, Y only	1-16
Figure 1-12: 625 Line Pluge 2, Y Channel Only	1-17
Figure 1-13: 525 Line Pluge 2, Y Only	1-17
Figure 1-14: 5-Step Staircase and Modulated 5-Step, Y	1-18
Figure 1-15: 5-Step Staircase, B-Y and R-Y	1-18
Figure 1-16: 625 Line Modulated 5-Step, B-Y and R-Y	1-19
Figure 1-17: 525 Line Modulated 5-Step, B-Y and R-Y	1-19
Figure 1-18: Limit Ramp, Y	1-20
Figure 1-19: Limit Ramp, B-Y and R-Y	1-20
Figure 1-20: Shallow Ramp, Y	1-21
Figure 1-21: Shallow Ramp, B-Y and R-Y	1-21
Figure 1-22: 625 Line Mod Pulse and Bar, Y	1-22
Figure 1-23: 625 Line Mod Pulse and Bar, B-Y	1-22
Figure 1-24: 625 Line Mod Pulse and Bar, R-Y	1-22
Figure 1-25: 525 Line Mod Pulse and Bar, Y	1-23
Figure 1-26: 525 Line Mod Pulse and Bar, B-Y	1-23
Figure 1-27: 525 Line Mod Pulse and Bar, R-Y	1-23
Figure 1-28: 60% Line Sweep with Markers, Y	1-24
Figure 1-29: 60% Line Sweep with Markers, B-Y and R-Y	1-24
Figure 1-30: 500 kHz Bowtie (reduced amplitude), Y	1-25
Figure 1-31: 500 kHz Bowtie (reduced amplitude), B-Y and R-Y ..	1-25
Figure 1-32: Bowtie Markers, Y Channel Only	1-26
Figure 1-33: Convergence, Vertical Lines; Y Channel Only	1-26
Figure 1-34: Convergence, Horizontal Lines; Y Only	1-27
Figure 1-35: Active Picture Markers, Vertical Limits, Y Channel ..	1-27
Figure 1-36: Active Picture Markers, Horizontal Limits	1-28
Figure 1-37: The Significance of the Active Picture Markers	1-28
Figure 3-1: Block Diagram of the TSG601	3-3

List of Tables

Table 1-1: Encoding Parameters	1-3
Table 1-2: Timing Relationships	1-4
Table 1-3: Test Signal Characteristics	1-7
Table 1-4: Serial Digital Video Output	1-10
Table 1-5: Cable Simulator	1-10

Table 1-6: Character Identification	1-11
Table 1-7: Power Supply	1-11
Table 1-8: Physical Characteristics	1-11
Table 1-9: Environmental Characteristics	1-12
Table 1-10: 75% and 100% Color Bars Timing	1-14
Table 1-11: Plug Timing	1-17
Table 1-12: 5-Step Staircase and Modulated 5-Step Timing	1-18
Table 1-13: Active Picture Markers Timing	1-28
Table 3-1: Circuit Addresses	3-2
Table 3-2: Low Battery Voltage Thresholds	3-4
Table 4-1: Required Equipment	4-1

General Safety Summary

Review the following safety precautions to avoid injury and prevent damage to this product or any products connected to it.

To avoid potential hazards, use this product only as specified.

Only qualified personnel should perform service procedures.

To Avoid Fire or Personal Injury

Use Proper Power Cord. Use only the power cord specified for this product and certified for the country of use.

Connect and Disconnect Properly. Do not connect or disconnect probes or test leads while they are connected to a voltage source.

Ground the Product. This product is grounded through the grounding conductor of the power cord. To avoid electric shock, the grounding conductor must be connected to earth ground. Before making connections to the input or output terminals of the product, ensure that the product is properly grounded.

Observe All Terminal Ratings. To avoid fire or shock hazard, observe all ratings and markings on the product. Consult the product manual for further ratings information before making connections to the product.

Power Disconnect. The power cord disconnects the product from the power source. Do not block the power cord; it must remain accessible to the user at all times.

Do Not Operate Without Covers. Do not operate this product with covers or panels removed.

Do Not Operate With Suspected Failures. If you suspect there is damage to this product, have it inspected by qualified service personnel.

Avoid Exposed Circuitry. Do not touch exposed connections and components when power is present.

Replace Batteries Properly. Replace batteries only with the specified type and rating.

Recharge Batteries Properly. Recharge batteries for the recommended charge cycle only.

Use Proper AC Adapter. Use only the AC adapter specified for this product.

Use Proper Fuse. Use only the fuse type and rating specified for this product.

Do Not Operate in Wet/Damp Conditions.

Do Not Operate in an Explosive Atmosphere.

Keep Product Surfaces Clean and Dry.

Terms in this Manual

These terms may appear in this manual:



WARNING. *Warning statements identify conditions or practices that could result in injury or loss of life.*



CAUTION. *Caution statements identify conditions or practices that could result in damage to this product or other property.*

Symbols and Terms on the Product

These terms may appear on the product:

- DANGER indicates an injury hazard immediately accessible as you read the marking.
- WARNING indicates an injury hazard not immediately accessible as you read the marking.
- CAUTION indicates a hazard to property including the product.

The following symbol(s) may appear on the product:



Service Safety Summary

Only qualified personnel should perform service procedures. Read this *Service Safety Summary* and the *General Safety Summary* before performing any service procedures.

Do Not Service Alone. Do not perform internal service or adjustments of this product unless another person capable of rendering first aid and resuscitation is present.

Disconnect Power. To avoid electric shock, switch off the instrument power, then disconnect the power cord from the mains power.

Use Care When Servicing With Power On. Dangerous voltages or currents may exist in this product. Disconnect power, remove battery (if applicable), and disconnect test leads before removing protective panels, soldering, or replacing components.

To avoid electric shock, do not touch exposed connections.



Specifications

Specifications

Introduction

The material in this section is organized into two main groupings: the specification tables and the supporting figures. The specification tables include:

- General signal characteristics and specifications.
- Signal level specifications.
- Power supply, physical, and environmental specifications.

The supporting figures (waveform diagrams and related data) follow the specification tables.

Reference Documentation

The following documents were used as references in the preparation of this section:

Product Classification Environmental Test Summary, 13 June 1977; Tektronix Standard 062-2853-00

Electromagnetic Compatibility Environmental Test, 31 March 1977; Tektronix Standard 062-2866-00

Recommendations and reports of the CCIR, 1978; Transmission of Sound Broadcasting and Television Signals Over Long Distances (CMTT)

IEEE Standard Dictionary of Electrical Terms, Second Edition (1977); IEEE Standard 100-1977

Safety Standard for Electrical and Electronic Test, Measuring Controlling and Related Equipment, February 1988; ANSI/ISA-S82.01

International Electrotechnical Commission Standard "Safety Requirements for Electronic Measuring Apparatus"; IEC 348

Canadian Standards Association Electrical Standard for Electrical and Electronic Measuring and Testing Equipment; CAN/CSA C22.2 No. 231

Standard for Electrical and Electronic Measuring and Testing Equipment, Second Edition, July 21, 1980

Performance Conditions

The Performance Requirements are valid if the instrument has been adjusted at approximately 25° C, is being operated within environmental limits (see Table 1-9), and has had a minimum warm-up of 20 minutes.

Safety Standard Compliance

The following safety standards apply to the TSG601:

- ANSI S82 — Safety Standard for Electrical and Electronic Test, Measuring, Controlling, and Related Equipment, 1988.
- CAN/CSA C22.2 No. 231 M89 — CSA Safety Requirements for Electrical and Electronic Measuring and Test Equipment.
- IEC1010-1 — Safety Requirements for Electrical Equipment for Measurement, Control, and Laboratory Use (1990).
- UL1244 — Standard for Electrical and Electronic Measuring and Testing Equipment, Second Edition (1980).

EMI Compliance

The following electromagnetic interference (EMI) standards apply to the TSG601:

- 47 CFR, Chapter 1 (FCC Rules), Part 15, Class A
- EN55103-1:1996 Product family standard for audio, video, audio-visual, and entertainment lighting control apparatus for professional use. Environment Class 4.
- EN55103-2:1996 Product family standard for audio, video, audio-visual, and entertainment lighting control apparatus for professional use. Environment Class 4.

NOTE. *Shielded cables were used in the certification of this instrument; therefore, shielded cables are recommended to be used when operating. (EC 92)*

Specification Tables

Table 1-1: Encoding Parameters

Characteristic	Performance Requirements	Supplemental Information
Standards Conformance		CCIR rec 601
Coded Signals		Y, B-Y, and R-Y
Samples Per Complete Line		525/60 625/50
Luminance (Y)		858 864
Color Difference (B-Y & R-Y)		429 432
Sampling Structure		Orthogonal, line, field, and picture repetitive. R-Y and B-Y samples co-sited with odd (1st, 3rd, 5th, etc.) Y samples in each line.
Sampling Frequency		
Luminance (Y)		13.5 MHz
B-Y and R-Y		6.75 MHz
Form of Coding		Uniformly quantized PCM, 10 bits per sample, for the luminance signal and each color difference signal.
Samples Per Digital Active Line		
Luminance (Y)		720
B-Y and R-Y		360
Correspondence Between Video Signal Levels and Quantization Levels		
Luminance (Y)		877 quantization levels with the black level (0 mV) corresponding to level 64 and the peak white level (700 mV) corresponding to level 940.
B-Y and R-Y		897 quantization levels in the center of the quantization scale (corresponding to ± 350 mV) with zero signal (0 mV) corresponding to level 512.

Table 1-2: Timing Relationships

Characteristics	Supplemental Information																																																																																																				
Standards Conformance	ANSI/SMPTE 125M, CCIR Rec 656, and EBU Tech 3267-E																																																																																																				
Line Timing 625/50 525/60	See Figure 1-1 See Figure 1-2																																																																																																				
Field Timing 625/50 525/60	See Figure 1-3 See Figure 1-4																																																																																																				
Timing Reference Signal EAV / SAV (* are protection bits)	<table border="1"> <thead> <tr> <th>Bit</th> <th>Preamble Signal</th> </tr> </thead> <tbody> <tr> <td>9 1 0 0 1</td> <td>Fixed</td> </tr> <tr> <td>8 1 0 0 F</td> <td>F = 1 during field 2 (change state when H = 1 in EAV). F = 0 during field 1.</td> </tr> <tr> <td>7 1 0 0 V</td> <td>V = 1 during vertical blanking (change state when H = 1 in EAV). V = 0 during active video.</td> </tr> <tr> <td>6 1 0 0 H</td> <td>H = 1 at start of horizontal blanking. H = 1 EAV. H = 0 SAV.</td> </tr> <tr> <td>5* 1 0 0 P3</td> <td rowspan="4">Hamming Code 6:3 Even parity bits 1 - 6</td> </tr> <tr> <td>4* 1 0 0 P2</td> </tr> <tr> <td>3* 1 0 0 P1</td> </tr> <tr> <td>2* 1 0 0 P0</td> </tr> <tr> <td>1* 0 0 0 0</td> <td></td> </tr> <tr> <td>0* 0 0 0 0</td> <td></td> </tr> </tbody> </table>	Bit	Preamble Signal	9 1 0 0 1	Fixed	8 1 0 0 F	F = 1 during field 2 (change state when H = 1 in EAV). F = 0 during field 1.	7 1 0 0 V	V = 1 during vertical blanking (change state when H = 1 in EAV). V = 0 during active video.	6 1 0 0 H	H = 1 at start of horizontal blanking. H = 1 EAV. H = 0 SAV.	5* 1 0 0 P3	Hamming Code 6:3 Even parity bits 1 - 6	4* 1 0 0 P2	3* 1 0 0 P1	2* 1 0 0 P0	1* 0 0 0 0		0* 0 0 0 0																																																																																		
Bit	Preamble Signal																																																																																																				
9 1 0 0 1	Fixed																																																																																																				
8 1 0 0 F	F = 1 during field 2 (change state when H = 1 in EAV). F = 0 during field 1.																																																																																																				
7 1 0 0 V	V = 1 during vertical blanking (change state when H = 1 in EAV). V = 0 during active video.																																																																																																				
6 1 0 0 H	H = 1 at start of horizontal blanking. H = 1 EAV. H = 0 SAV.																																																																																																				
5* 1 0 0 P3	Hamming Code 6:3 Even parity bits 1 - 6																																																																																																				
4* 1 0 0 P2																																																																																																					
3* 1 0 0 P1																																																																																																					
2* 1 0 0 P0																																																																																																					
1* 0 0 0 0																																																																																																					
0* 0 0 0 0																																																																																																					
Protection Bit States	<table border="1"> <thead> <tr> <th>1</th> <th>F</th> <th>V</th> <th>H</th> <th>P3</th> <th>P2</th> <th>P1</th> <th>P0</th> <th colspan="2"></th> </tr> <tr> <th>9</th> <th>8</th> <th>7</th> <th>6</th> <th>5</th> <th>4</th> <th>3</th> <th>2</th> <th>1</th> <th>0</th> </tr> </thead> <tbody> <tr> <td>1</td> <td>0</td> <td>0</td> <td>0</td> <td>0</td> <td>0</td> <td>0</td> <td>0</td> <td>0</td> <td>0</td> </tr> <tr> <td>1</td> <td>0</td> <td>0</td> <td>1</td> <td>1</td> <td>1</td> <td>0</td> <td>1</td> <td>0</td> <td>0</td> </tr> <tr> <td>1</td> <td>0</td> <td>1</td> <td>0</td> <td>1</td> <td>0</td> <td>1</td> <td>1</td> <td>0</td> <td>0</td> </tr> <tr> <td>1</td> <td>0</td> <td>1</td> <td>1</td> <td>0</td> <td>1</td> <td>1</td> <td>0</td> <td>0</td> <td>0</td> </tr> <tr> <td>1</td> <td>1</td> <td>0</td> <td>0</td> <td>0</td> <td>1</td> <td>1</td> <td>1</td> <td>0</td> <td>0</td> </tr> <tr> <td>1</td> <td>1</td> <td>0</td> <td>1</td> <td>1</td> <td>0</td> <td>1</td> <td>0</td> <td>0</td> <td>0</td> </tr> <tr> <td>1</td> <td>1</td> <td>1</td> <td>0</td> <td>1</td> <td>1</td> <td>0</td> <td>0</td> <td>0</td> <td>0</td> </tr> <tr> <td>1</td> <td>1</td> <td>1</td> <td>1</td> <td>0</td> <td>0</td> <td>0</td> <td>1</td> <td>0</td> <td>0</td> </tr> </tbody> </table>	1	F	V	H	P3	P2	P1	P0			9	8	7	6	5	4	3	2	1	0	1	0	0	0	0	0	0	0	0	0	1	0	0	1	1	1	0	1	0	0	1	0	1	0	1	0	1	1	0	0	1	0	1	1	0	1	1	0	0	0	1	1	0	0	0	1	1	1	0	0	1	1	0	1	1	0	1	0	0	0	1	1	1	0	1	1	0	0	0	0	1	1	1	1	0	0	0	1	0	0
1	F	V	H	P3	P2	P1	P0																																																																																														
9	8	7	6	5	4	3	2	1	0																																																																																												
1	0	0	0	0	0	0	0	0	0																																																																																												
1	0	0	1	1	1	0	1	0	0																																																																																												
1	0	1	0	1	0	1	1	0	0																																																																																												
1	0	1	1	0	1	1	0	0	0																																																																																												
1	1	0	0	0	1	1	1	0	0																																																																																												
1	1	0	1	1	0	1	0	0	0																																																																																												
1	1	1	0	1	1	0	0	0	0																																																																																												
1	1	1	1	0	0	0	1	0	0																																																																																												

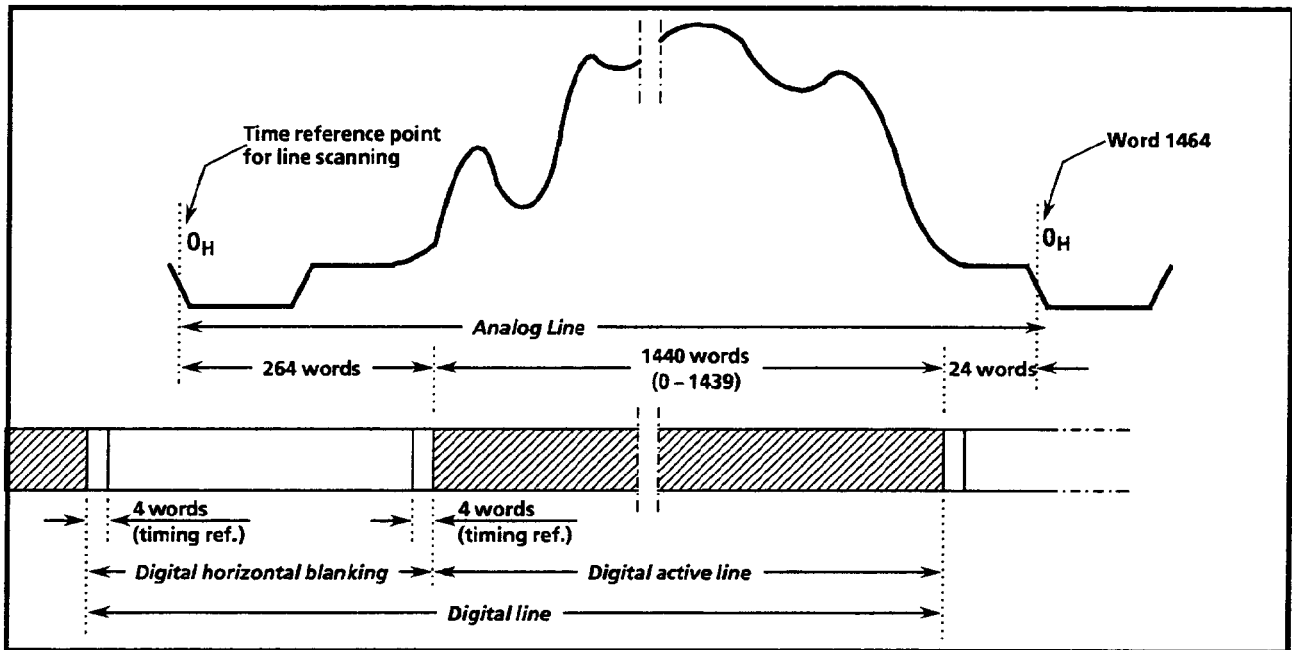

Figure 1-1: Analog/Digital Line Timing, 625/50 Systems

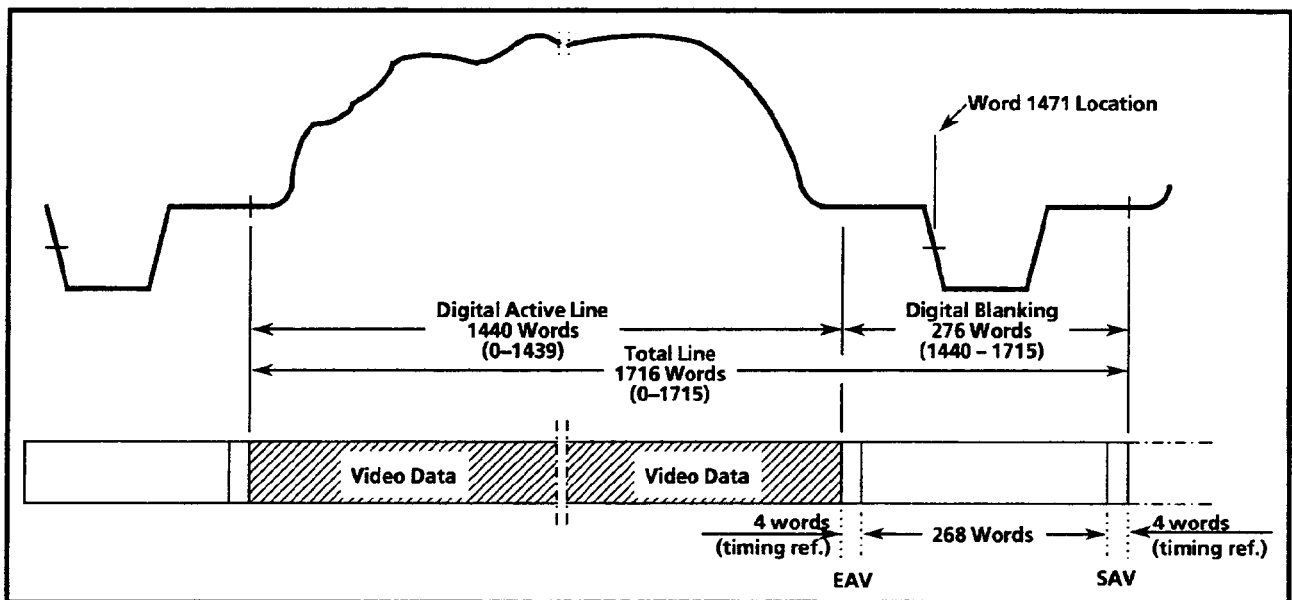

Figure 1-2: Analog/Digital Line Timing, 525/60 Systems

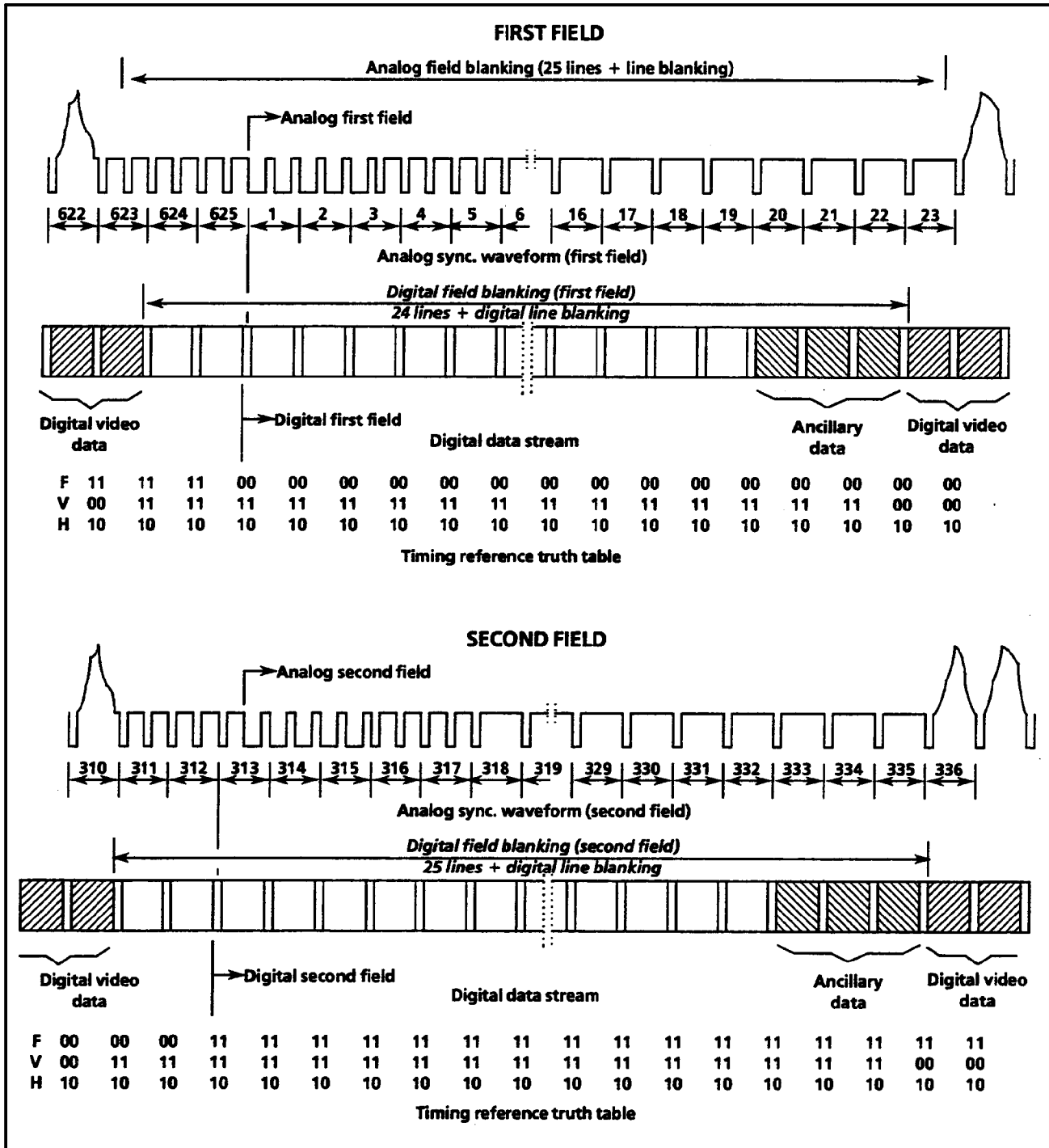

Figure 1-3: Analog/Digital Field Timing, 625-line Systems

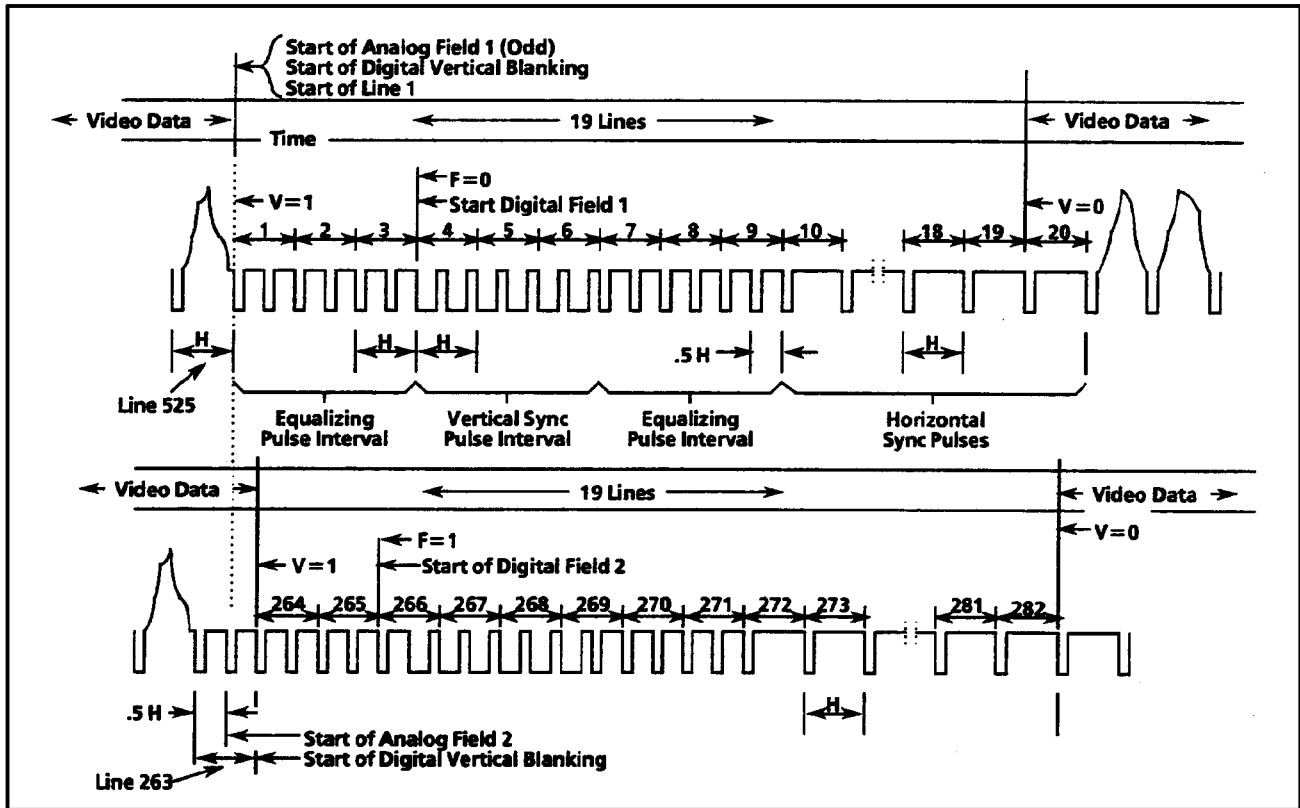

Figure 1-4: Analog/Digital Field Timing, 525-line Systems

Table 1-3: Test Signal Characteristics

Characteristic	Supplemental Information
75% Color Bars	See Figures 1-5, 1-6, and 1-7, and Table 1-10
100% Color Bars	See Figures 1-8, 1-9, and 1-10, and Table 1-10
Pluge (BBC 1)	See Figure 1-11 and Table 1-11
Field Timing, 625/50	
700 mV	Lines 83-166
105 mV	Lines 167-250
Field Timing, 525/60	
700 mV	Lines 72-142
105 mV	Lines 143-212

Table 1-3: Test Signal Characteristics (Cont.)

Characteristic	Supplemental Information
Pluge (BBC 2)	See Figures 1-12 and 1-13, and Table 1-11
Field Timing, 625/50	
700 mV	Lines 63-114
450 mV	Lines 115-166
200 mV	Lines 167-218
110 mV	Lines 219-270
Field Timing, 525/60	
700 mV	Lines 55-98
450 mV	Lines 99-142
200 mV	Lines 143-185
110 mV	Lines 186-229
5-Step Staircase	See Figures 1-14 and 1-15, and Table 1-12
Amplitude	
Y Channel	0 to 702.4 mV in 176-word steps
B-Y, R-Y	-351.6 to +351.6 mV in 180-word steps
Mod 5-Step	See Figures 1-14, 1-16, and 1-17; and Table 1-12
Amplitude	
Y Channel	0 to 702.4 mV in 176-word steps
525 B-Y, R-Y	-157.3 mV
625 B-Y	83.7 mV
625 R-Y	94.4 mV
Limit Ramp	See Figures 1-18 and 1-19
	In 8-bit, extends from word 01 to 254;
	in 10-bit, extends from word 04 to 1016.
Shallow Ramp	See Figures 1-20 and 1-21
Amplitude	80 mV
Pedestal (variable)	
Y Channel	0 to 700 mV
B-Y, R-Y	-350 to +350 mV
Rise Times	
Y Channel	200 ns
B-Y, R-Y	280 ns
Mod Pulse and Bar (625 lines/50 Hz)	See Figures 1-22, 1-23, and 1-24
4T Pulse HAD	400 ns
10T Pulse HAD	1000 ns (1.0 μ s)
Pulse Amplitude	
Y	350.0 mV
B-Y	196.3 mV
R-Y	248.1 mV
2T Pulse HAD	200 ns (Y channel only)

Table 1-3: Test Signal Characteristics (Cont.)

Characteristic	Supplemental Information
Mod Pulse and Bar (525 lines/60 Hz)	See Figures 1-25, 1-26, and 1-27
12.5T Pulse HAD	1562.5 ns (in NTSC, encodes to 12.5T modulated pulse, $\phi = 60.7^\circ$)
Pulse Amplitude	
Y Channel	350.0 mV
B-Y	196.3 mV
R-Y	248.1 mV
2T Pulse HAD	200 ns (Y channel only)
60% Line Sweep With Markers	See Figures 1-28 and 1-29
Amplitude	420 mV
Frequency Range	
Y Channel	250 kHz-5.75 MHz
R-Y, B-Y	125 kHz-2.75 MHz
Marker Frequencies	
Y Channel	0.5, 1, 2, 3, 4, and 5 MHz
R-Y, B-Y	0.25, 0.5, 1, 1.5, 2, and 2.5 MHz
500 kHz Bowtie (half amplitude)	See Figures 1-30, 1-31, and 1-32
Y Channel	500 kHz sine wave
R-Y, B-Y	502 kHz sine wave
Amplitude	350 mV
Convergence	See Figures 1-33 and 1-34
Amplitude	525 mV (75%)
Pattern	Crosshatch: 14 horiz./15 vert. lines
Pulse HAD	225 \pm 25 ns
Equalizer SDI Checkfield	Per SMPTE RP 178
PLL SDI Checkfield	Per SMPTE RP 178
Matrix SDI Checkfield	Per SMPTE RP 178
Field Timing, 625/50	
Equalizer	Lines 24 through 166
PLL	Lines 167 through 310
Field Timing, 525/60	
Equalizer	Lines 21 through 141
PLL	Lines 142 through 262
Active Picture Markers	See Figures 1-35, 1-36, and 1-37, and Table 1-13
Field Timing, 625/50	
Vertical Limits	Lines 24 and 310
Horizontal Limits	Lines 25 through 309
Field Timing, 525/60	
Vertical Limits	Lines 21 and 262
Horizontal Limits	Lines 22 through 261

Table 1-4: Serial Digital Video Output

Characteristic	Performance Requirements	Supplemental Information
Connectors		3 BNCs, 75 Ω
Number of Outputs		1 component serial video
Digital Format		CCIR 601 Component 525/625, 8 or 10 bits data, Scrambled NRZI; complies with SMPTE 259M and CCIR 656.
Bit Rate		270 Mb/s
Source Impedance		75 Ω
Return Loss		≥ 15 dB from 5 MHz to 270 MHz instrument switched on
Termination Detector		Triggers display  symbol when return loss of the signal path is ≤ 10 dB (approximates termination impedance of $\leq 37.5 \Omega$ and $\geq 150 \Omega$)
Signal Amplitude		Variable from 600 mV to 1000 mV in the following steps Coarse: 100 mV on even 100 mV increments Fine: 20 mV increments
Absolute Accuracy @ 800 mV setting	800 ± 20 mV	
Relative Accuracy Coarse increments	100 ± 8 mV	From last 100 mV setting
Fine increments	20 ± 8 mV	
DC Offset	0 ± 0.5 Volts	
Rise and Fall Times	400-1000 ps	20% to 80% amplitude points
Jitter	less than ± 360 ps	Over a period of one line.
Error Detection Ancillary Data		Active picture CRC (0-AP-CRC, Tektronix proprietary) on lines 9 & 272 (525) or 5 & 318 (625). EDH (SMPTE RP-165)

Table 1-5: Cable Simulator

Characteristic	Performance Requirements	Supplemental Information
Length		-5.4 dB \pm 0.5 dB at 135 MHz (Approximates a 50 meter length of Belden 8281 coax cable)
Return Loss	≥ 20 dB from 5 MHz to 270 MHz	

Table 1-6: Character Identification

Characteristic	Information
Number of Characters Displayed	Two lines of up to 16 Characters per line.
Display Position	Moveable over the Safe Action area of the field.
Character Amplitude	Black, 70 mV equivalent White, 630 mV equivalent

Table 1-7: Power Supply

Characteristic	Performance Requirements	Supplemental Information
DC Input Range	9 to 15 VDC	
Supply Accuracy + 5 D + 5 A	+5 V \pm 250 mV +5 V \pm 250 mV	
Hum + 5 D + 5 A	\leq 25 mV \leq 25 mV	
Noise + 5 D +5 A	\leq 50 mV \leq 20 mV	\leq 5 MHz Bandwidth
Fuse		4 A fast blow, 32 V min
Power Limit Without adapter With adapter		5.0 W 6.0 W
Power Consumption Back light off Back light on		Typical: 4.0 W 4.5 W

Table 1-8: Physical Characteristics

Characteristic	Information
Height	5.6 cm (2.2 in)
Width	9.1 cm (3.6 in)
Depth	19.1 cm (7.5 in)
Net Weight TSG 601 TSG 601 with battery pack	0.48 kg (1.06 lb) 0.68 kg (1.5 lb)
Shipping Weight (with AC adapter)	1.50 kg (3.31 lb)

Table 1-9: Environmental Characteristics

Characteristic	Information
Temperature Operating Storage	0° C to +35° C (32 to +95° F) -30° C to +65° C (-22 to +149° F)
Altitude Operating Storage	to 15,000 feet (4572 m); IEC 1010-1 compliance to 2000 m to 50,000 feet (15420 m)
Equipment Type	Test
Equipment Class	Class III (as defined in IEC 1010-1, Annex H)
Installation Category	Category II (as defined in IEC 1010-1, Annex J) Note: Rated for indoor use only.
Pollution Degree	Pollution Degree 2 (as defined in IEC 1010-1)
Transportation	Meets the requirements of NTSB Test Procedure 1A, category II (24 inch drop)

Certifications and Compliances

EC Declaration of Conformity - EMC

Meets intent of Directive 89/336/EEC for Electromagnetic Compatibility. Compliance was demonstrated to the following specifications as listed in the Official Journal of the European Communities:

EN 55103. Product family standard for audio, video, audio-visual and entertainment lighting control apparatus for professional use.

- Environment E4 — controlled EMC environment
- Part 1 Emission
 - EN 55022. Class A radiated and conducted emissions
 - EN 55103-1 Annex A. Radiated magnetic field emissions
 - EN 55103-1 Annex B. Inrush current
- Part 2 Immunity
 - IEC 61000-4-2. Electrostatic discharge immunity
 - IEC 61000-4-3. RF electromagnetic field immunity
 - IEC 61000-4-4. Electrical fast transient / burst immunity
 - IEC 61000-4-5. Power line surge immunity
 - IEC 61000-4-6. Conducted RF Immunity

- IEC 61000-4-11. Voltage dips and interruptions immunity
- EN 55103-2 Annex A. Radiated magnetic field immunity
- EN 55103-2 Annex B. Balanced ports common mode immunity

EN 61000-3-2. AC power line harmonic emissions

**Australia / New Zealand
Declaration of Conformity
- EMC**

Complies with EMC provision of Radiocommunications Act per these standard(s):

- AS/NZS 2064.1/2. Industrial, Scientific, and Medical Equipment: 1992

Waveform Diagrams

NOTE. The following diagrams represent the analog equivalents of the TSG601 digital test signals. Horizontal axis units are microseconds after the start of Digital Active Video. Unless specified in the caption, each illustration represents both 525 line/60 Hz and 625/50 Hz signals.

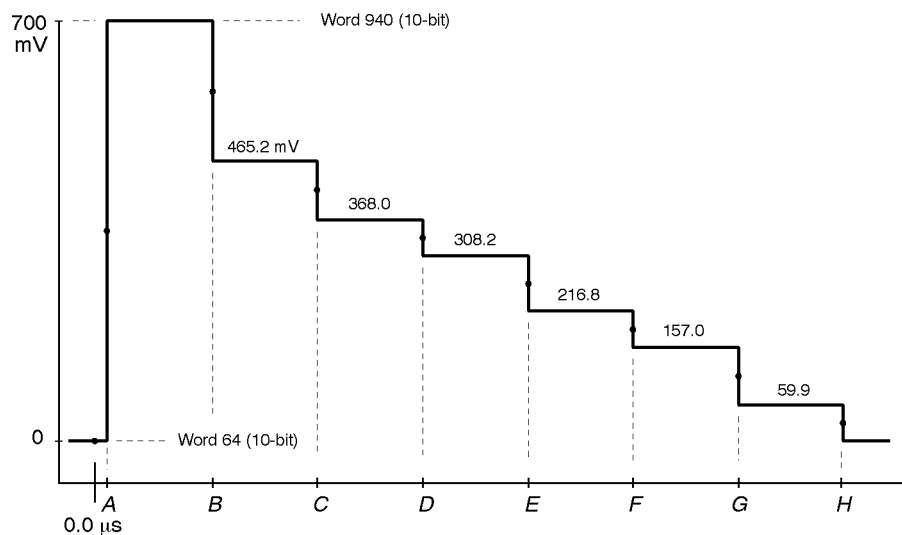

Figure 1-5: 75% Color Bars, Y

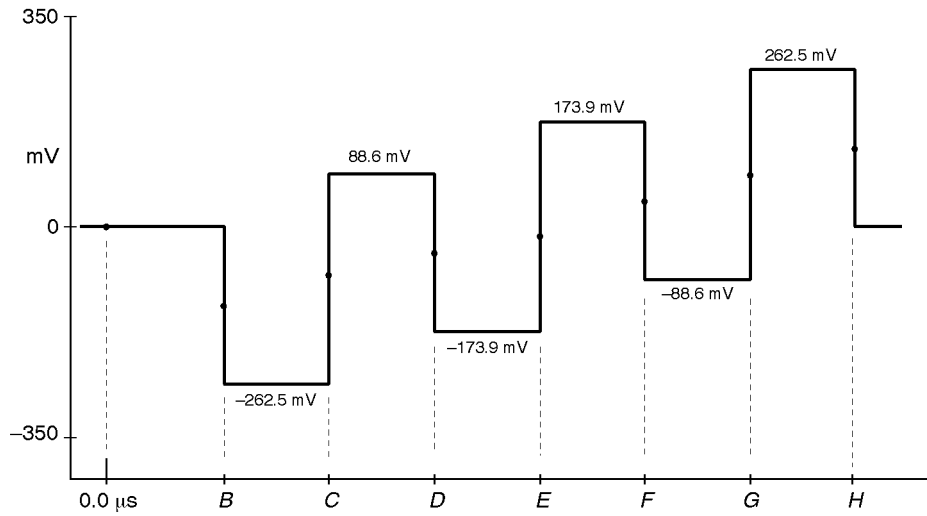

Figure 1-6: 75% Color Bars, B-Y

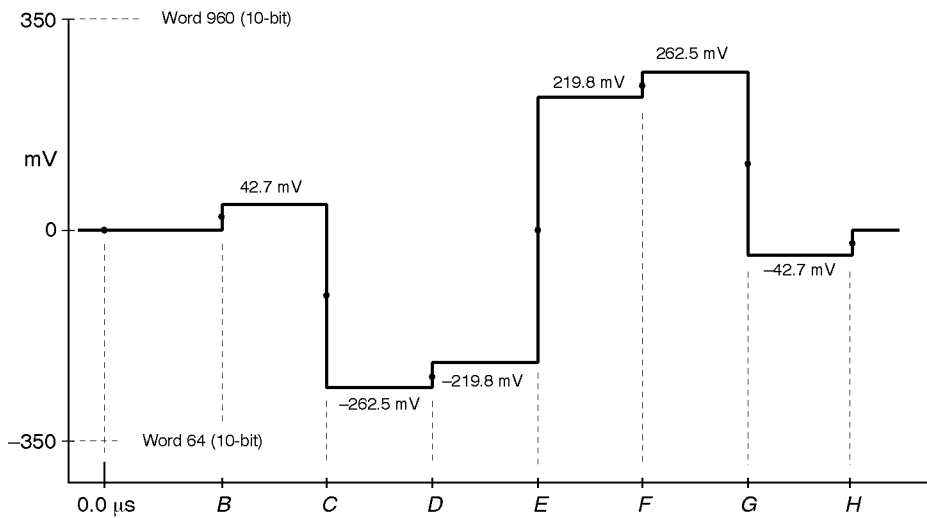

Figure 1-7: 75% Color Bars, R-Y

Table 1-10: 75% and 100% Color Bars Timing

	A	B	C	D	E	F	G	H
625/50	0.74 μ s	7.26	13.70	20.22	26.74	33.18	39.70	46.15
525/60	0.37	6.96	13.56	20.07	26.67	33.26	39.85	46.37

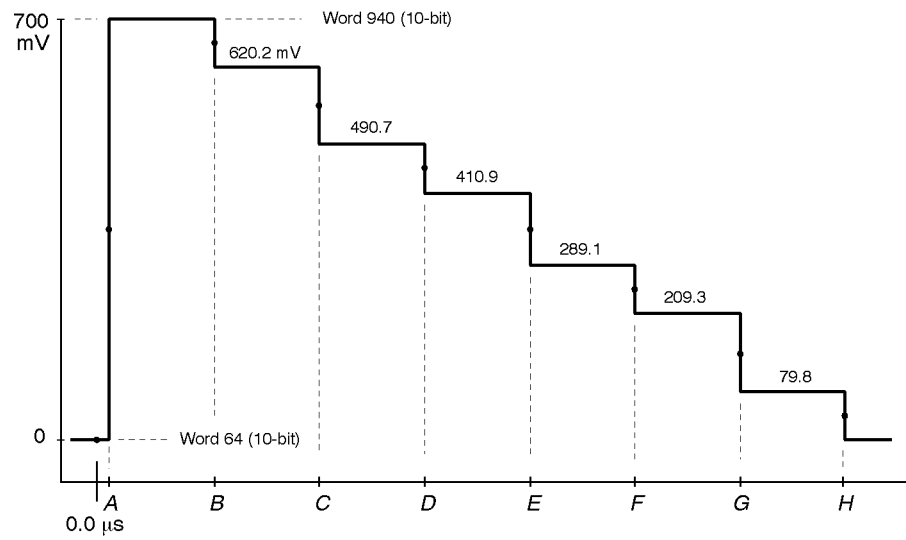

Figure 1-8: 100% Color Bars, Y

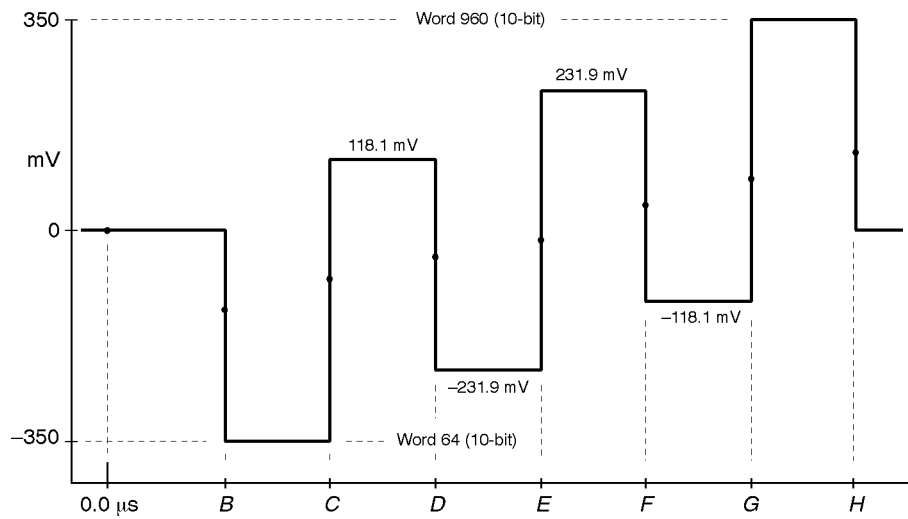

Figure 1-9: 100% Color Bars, B-Y

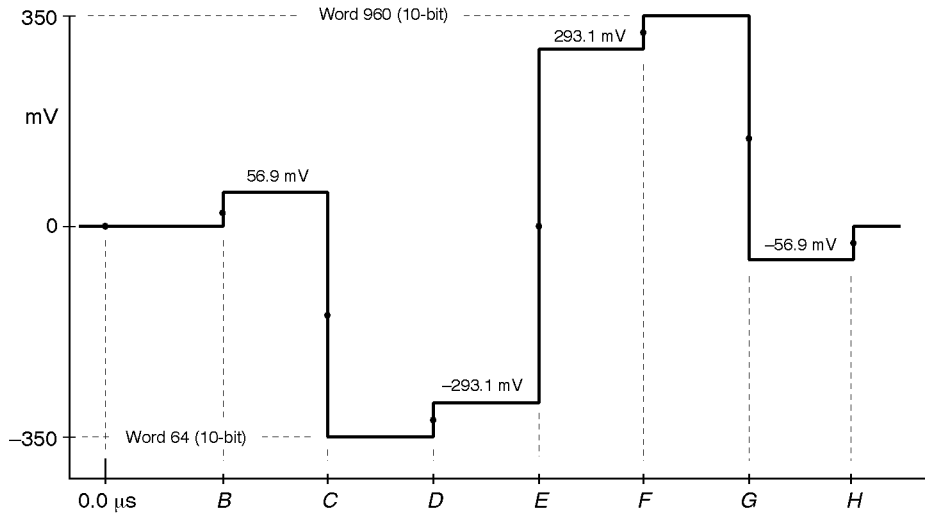

Figure 1-10: 100% Color Bars, R-Y

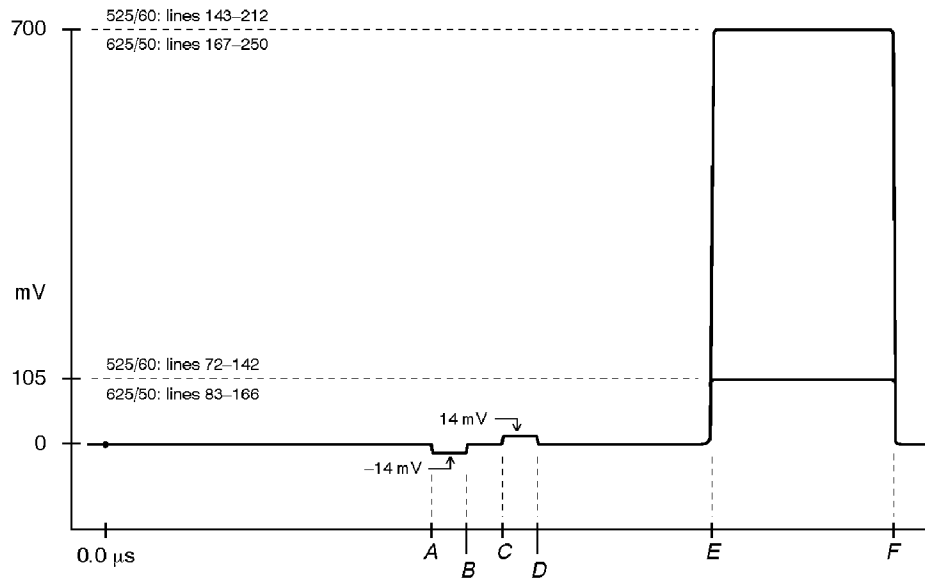

Figure 1-11: Pluge 1, Y only

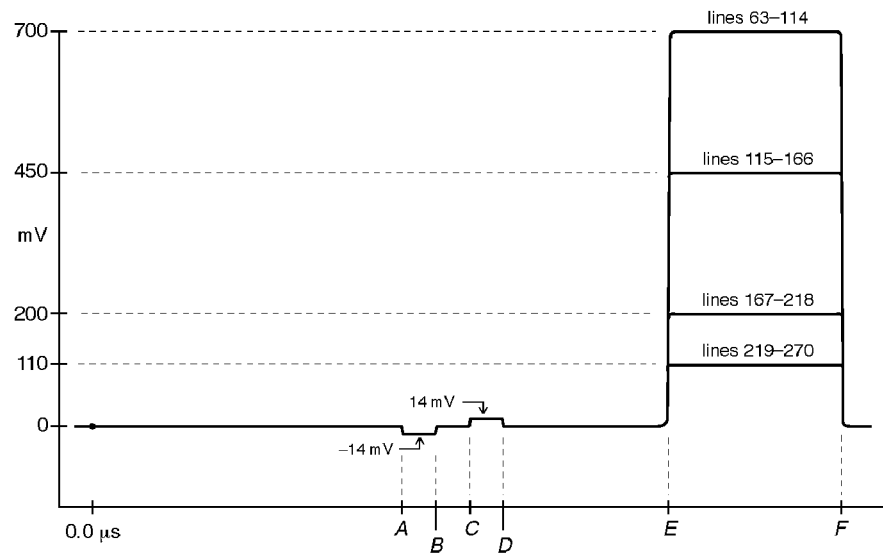

Figure 1- 12: 625 Line Pluge 2, Y Channel Only

Table 1- 11: Pluge Timing

	A	B	C	D	E	F
625 & 525	21.57 μ s	23.87	26.17	28.47	40.07	52.07

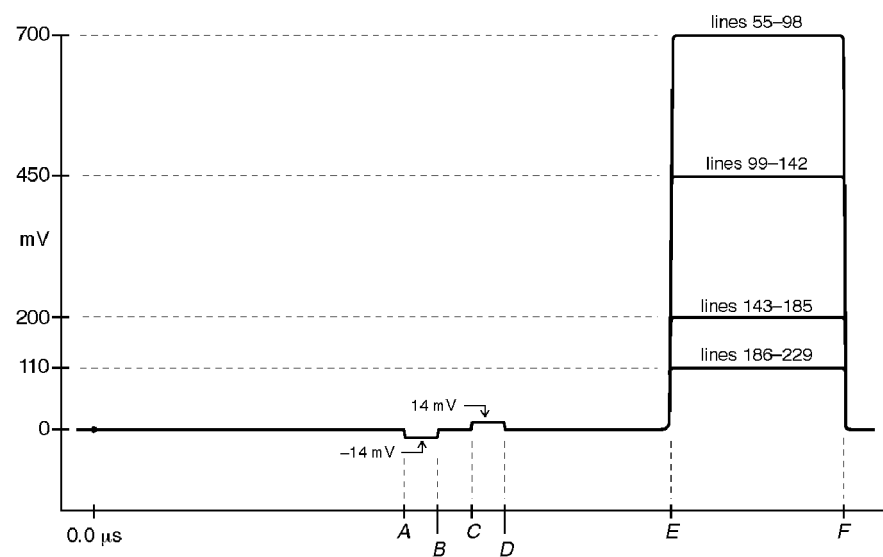

Figure 1- 13: 525 Line Pluge 2, Y Only

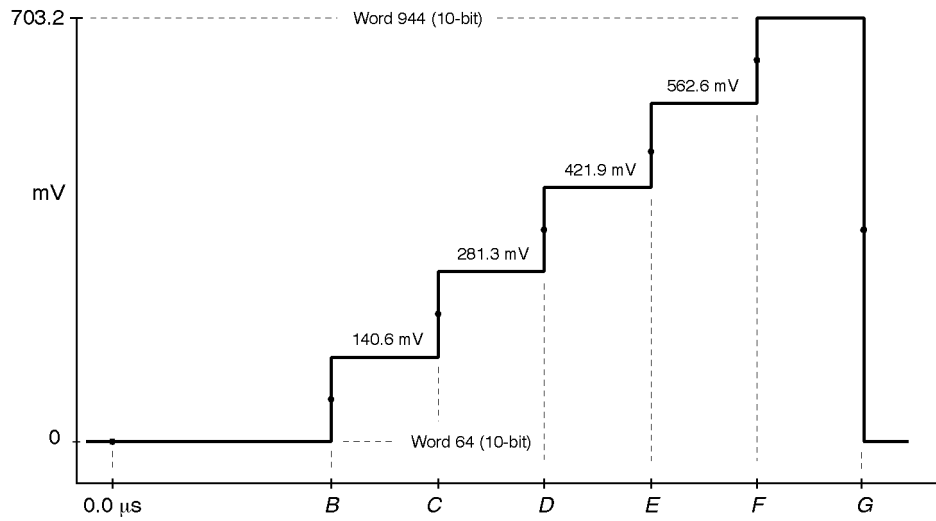

Figure 1-14: 5-Step Staircase and Modulated 5-Step, Y

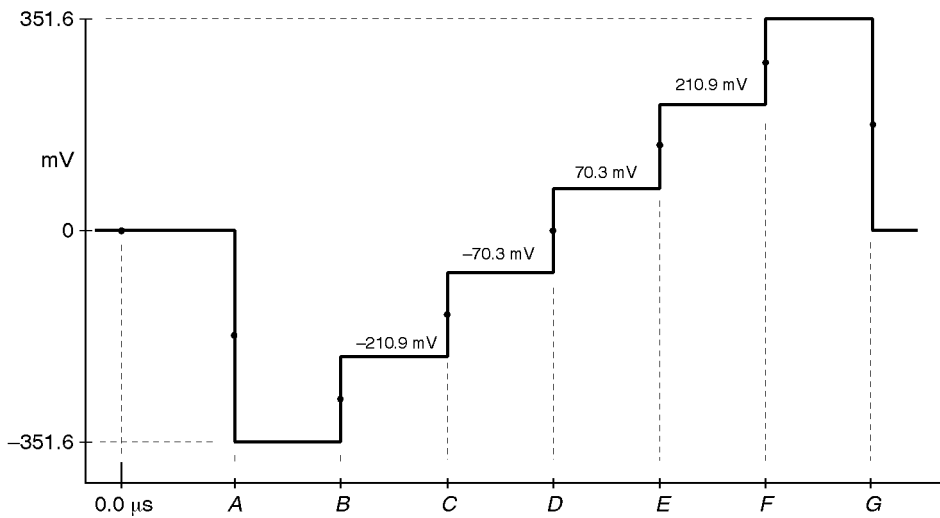

Figure 1-15: 5-Step Staircase, B- Y and R- Y

Table 1-12: 5-Step Staircase and Modulated 5-Step Timing

	A	B	C	D	E	F	G
625 & 525	6.96 μ s	13.48	20.07	26.59	33.18	39.70	46.30

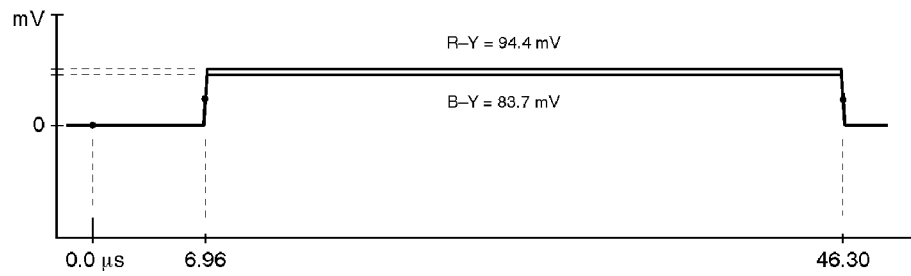

Figure 1-16: 625 Line Modulated 5-Step, B-Y and R-Y

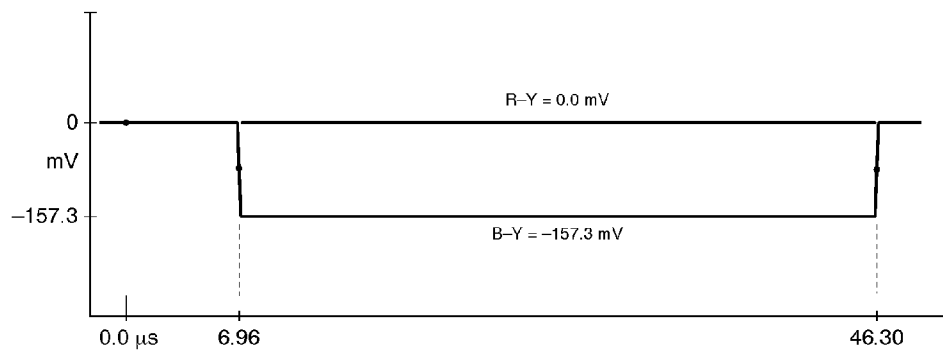

Figure 1-17: 525 Line Modulated 5-Step, B-Y and R-Y

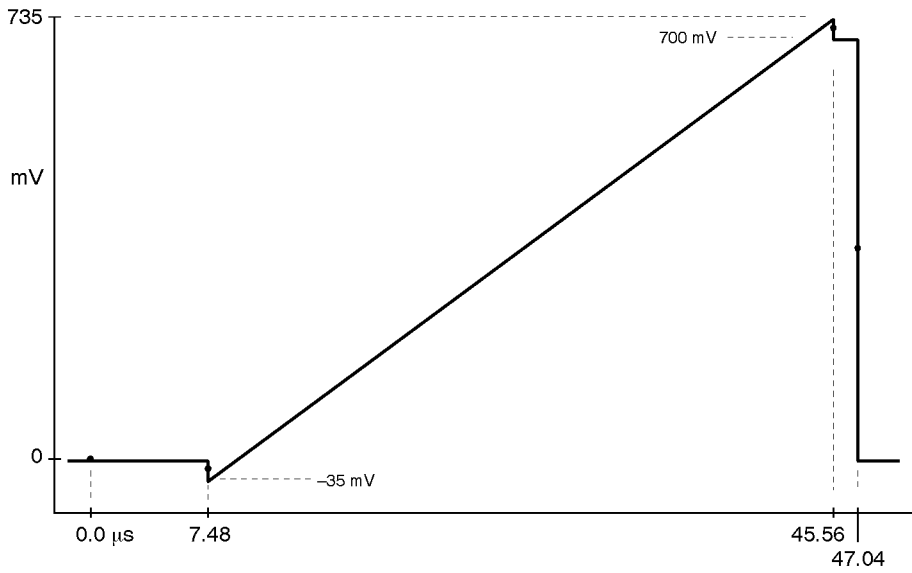

Figure 1-18: Limit Ramp, Y

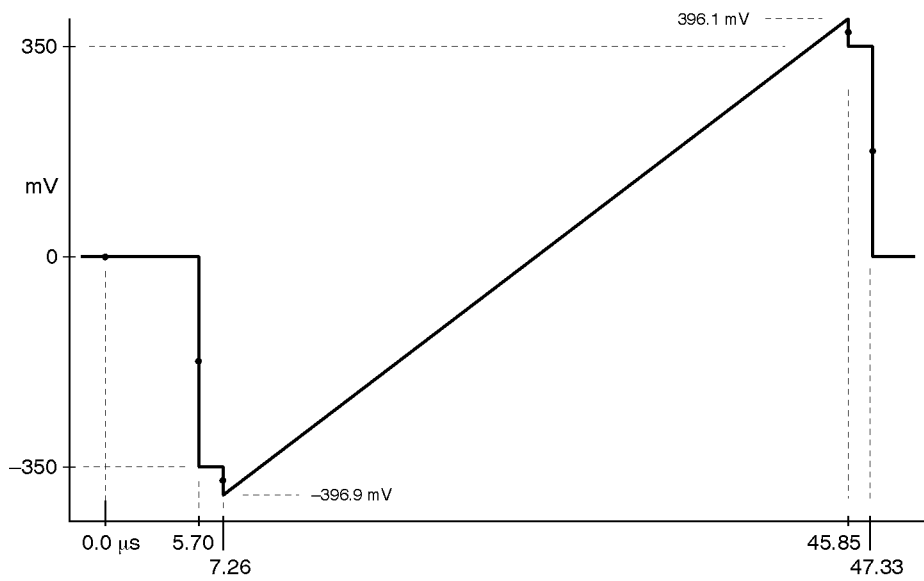

Figure 1-19: Limit Ramp, B-Y and R-Y

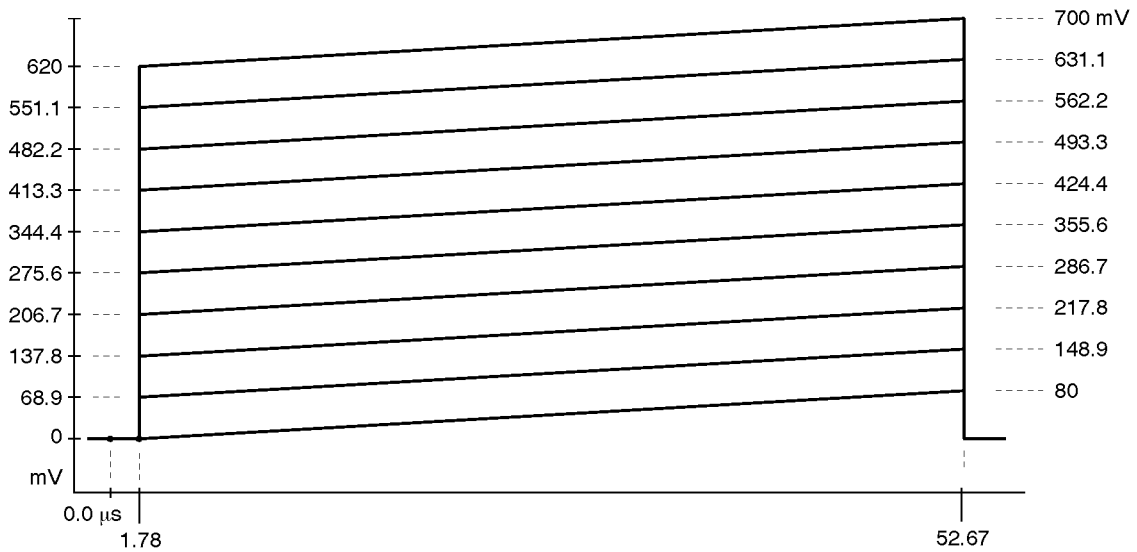

Figure 1-20: Shallow Ramp, Y

NOTE. You may set the shallow ramp pedestal to one of the ten levels shown. To do so, use the ◀ and ▶ keys to select from levels 0 through 9 when the TSG601 is in normal operation and the Shallow ramp is “active.”



Figure 1-21: Shallow Ramp, B-Y and R-Y

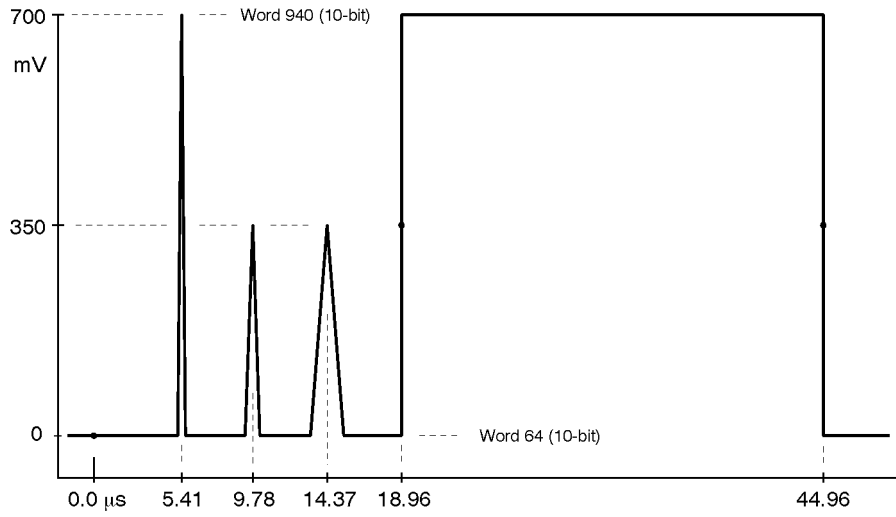

Figure 1-22: 625 Line Mod Pulse and Bar, Y

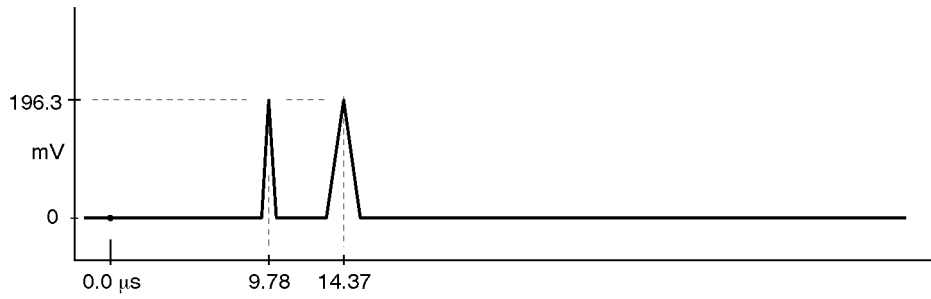

Figure 1-23: 625 Line Mod Pulse and Bar, B-Y

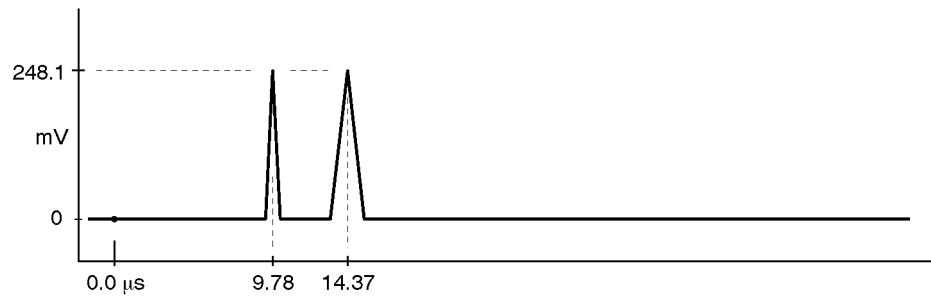

Figure 1-24: 625 Line Mod Pulse and Bar, R-Y

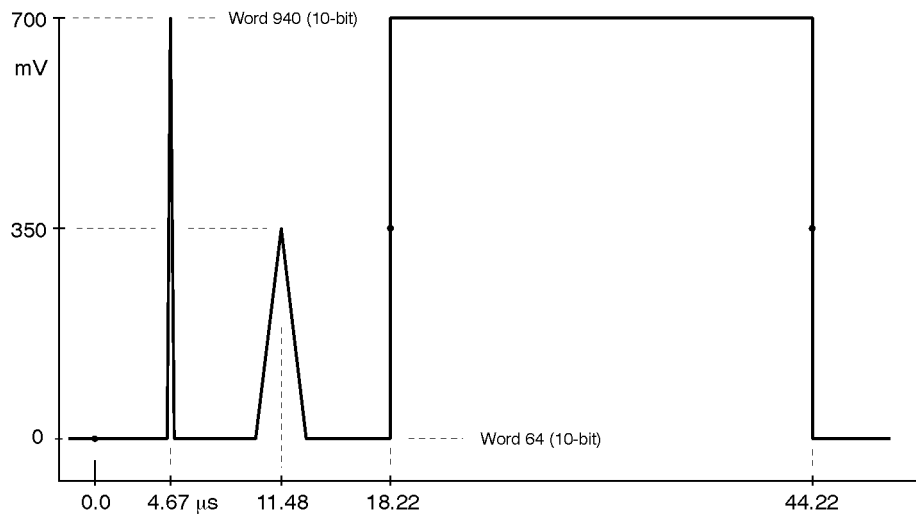

Figure 1-25: 525 Line Mod Pulse and Bar, Y

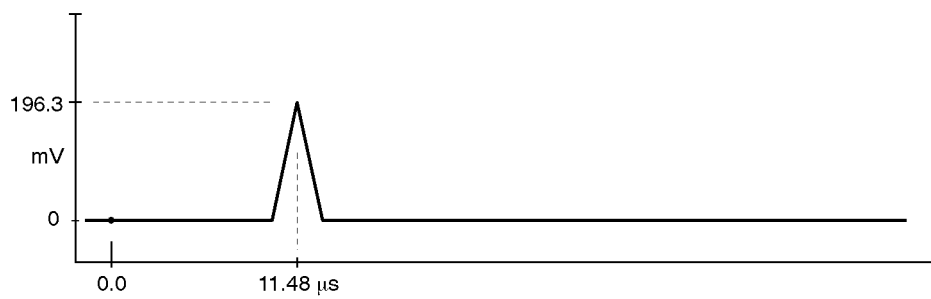

Figure 1-26: 525 Line Mod Pulse and Bar, B-Y

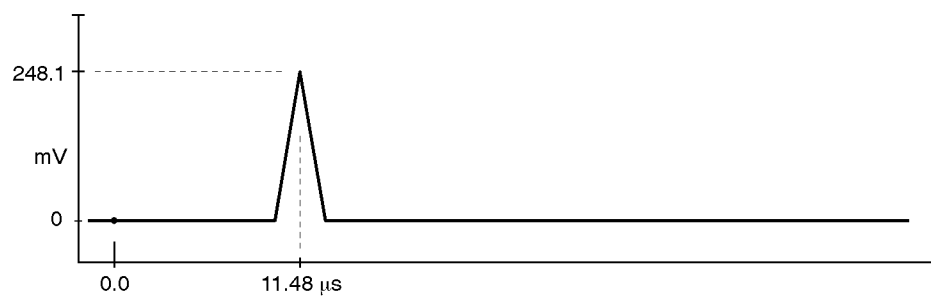

Figure 1-27: 525 Line Mod Pulse and Bar, R-Y

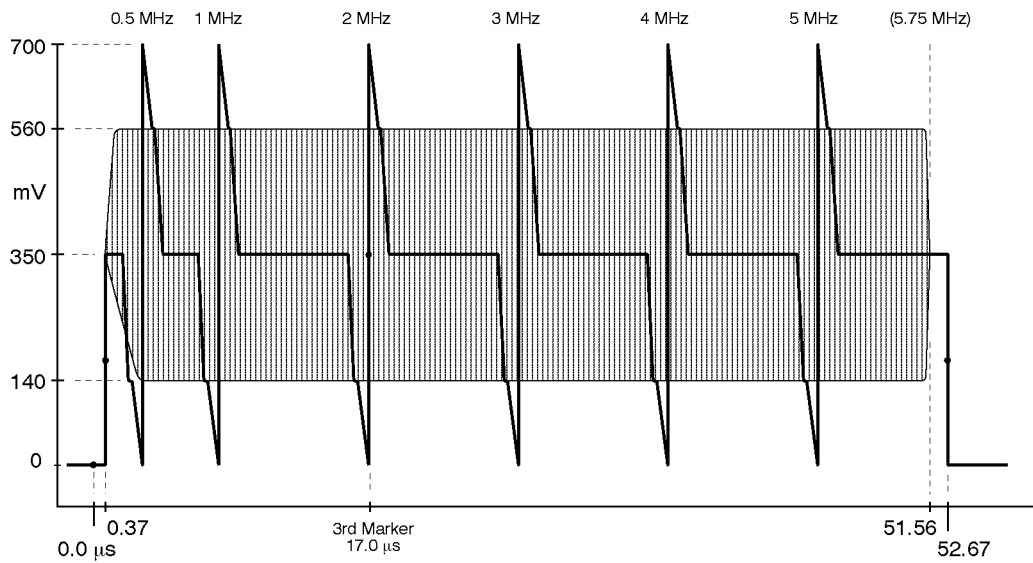

Figure 1-28: 60% Line Sweep with Markers, Y

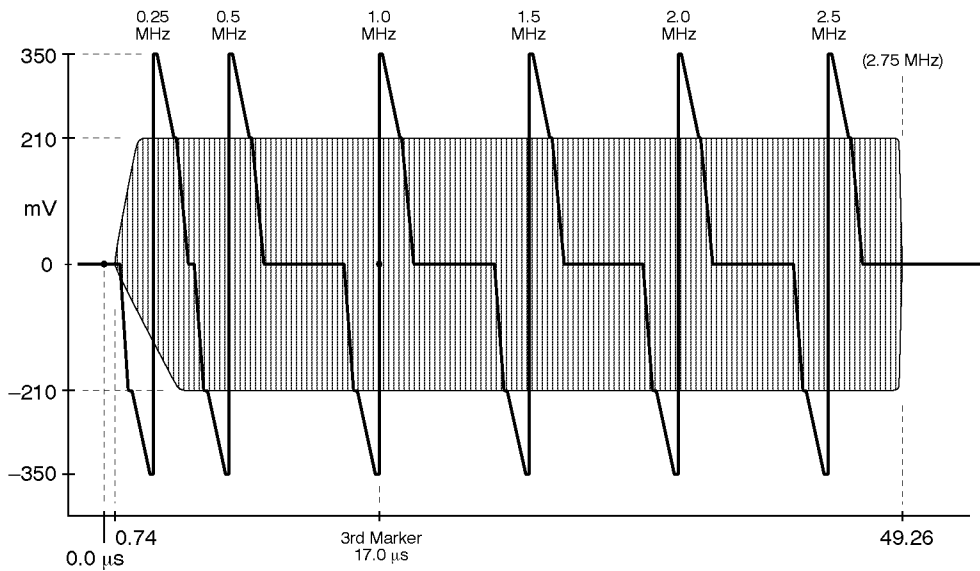

Figure 1-29: 60% Line Sweep with Markers, B-Y and R-Y

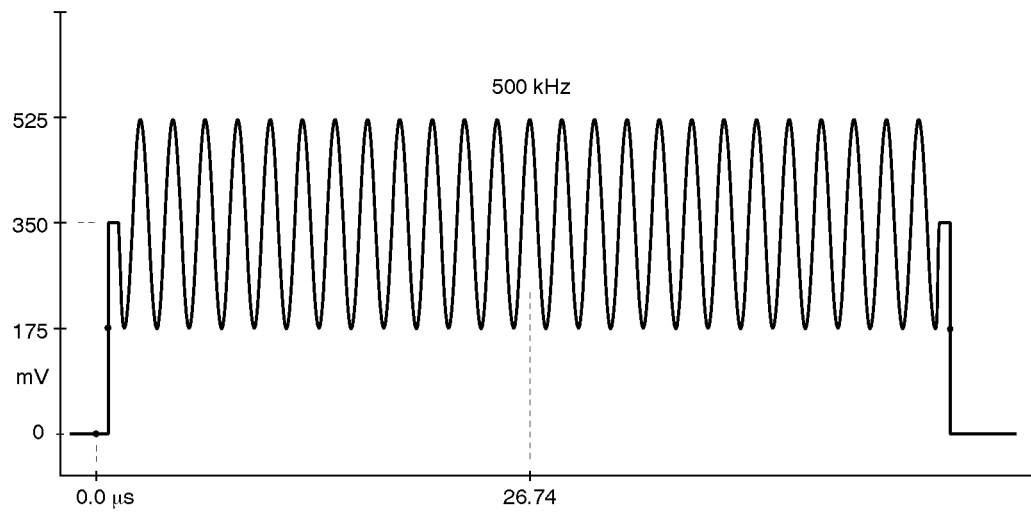

Figure 1-30: 500 kHz Bowtie (reduced amplitude), Y

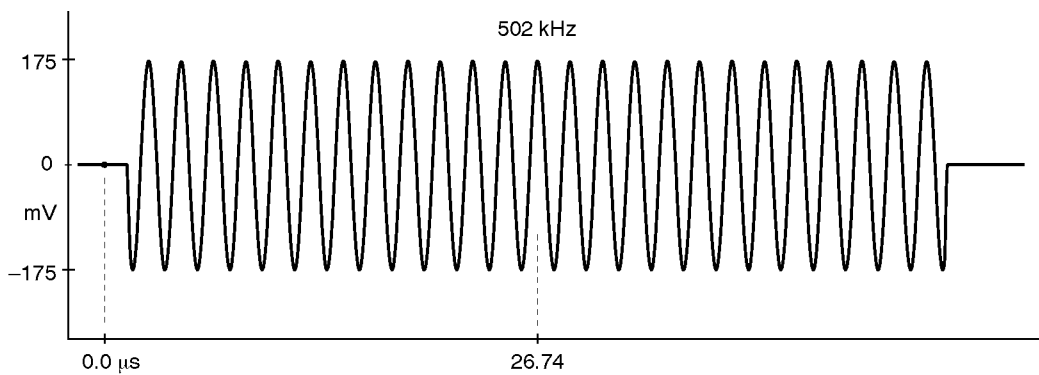

Figure 1-31: 500 kHz Bowtie (reduced amplitude), B-Y and R-Y

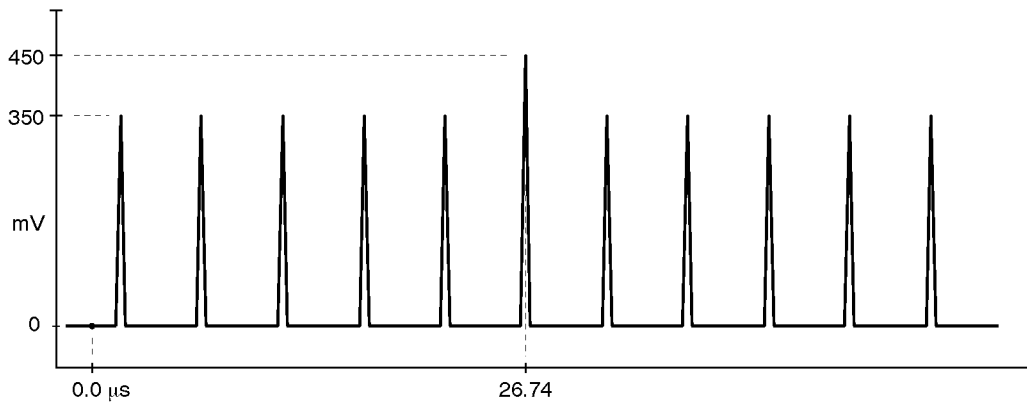

Figure 1-32: Bowtie Markers, Y Channel Only

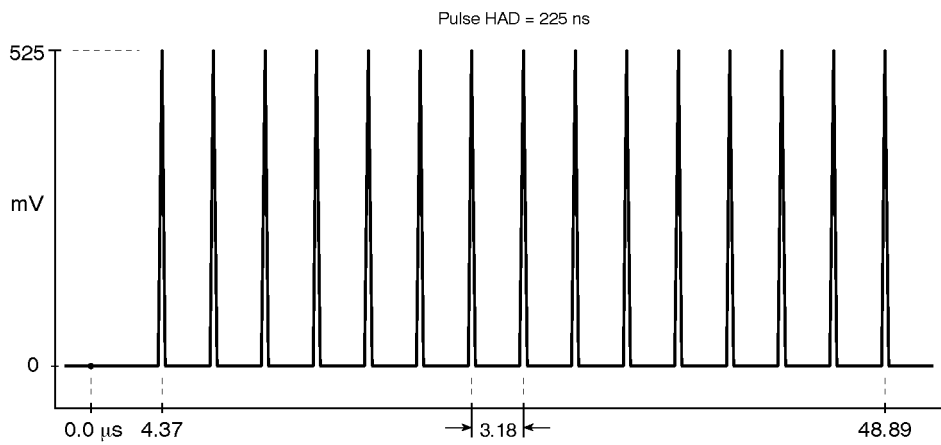

Figure 1-33: Convergence, Vertical Lines; Y Channel Only

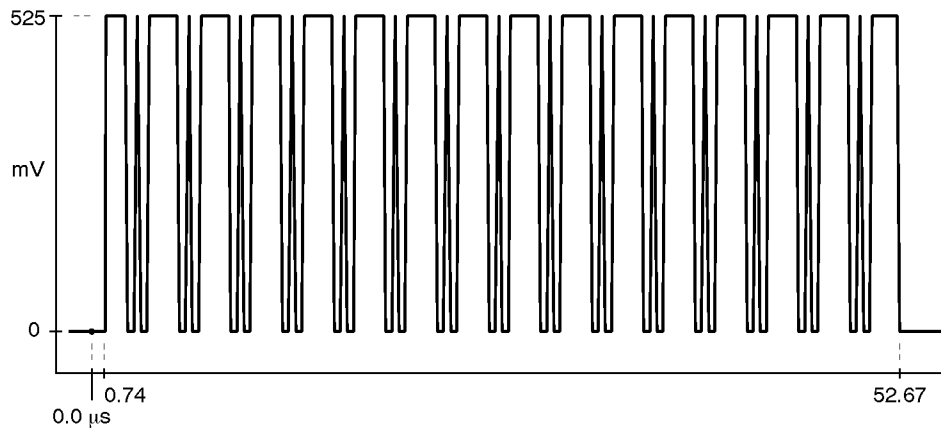

Figure 1-34: Convergence, Horizontal Lines; Y Only



Figure 1-35: Active Picture Markers, Vertical Limits, Y Channel Only

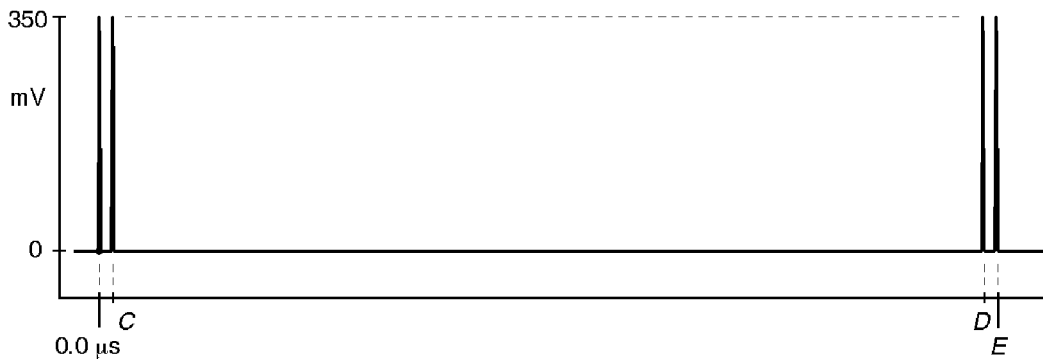

Figure 1-36: Active Picture Markers, Horizontal Limits, All Channels

Table 1-13: Active Picture Markers Timing

	A	B	C	D	E
625/50: Y	0.72 μ s	52.72	1.04	52.44	53.26
625/50: B-Y and R-Y	—	—	1.04	52.44	53.18
525/60: Y	0.16	53.02	0.29	52.89	53.26
525/60: B-Y and R-Y	—	—	0.29	52.89	53.18

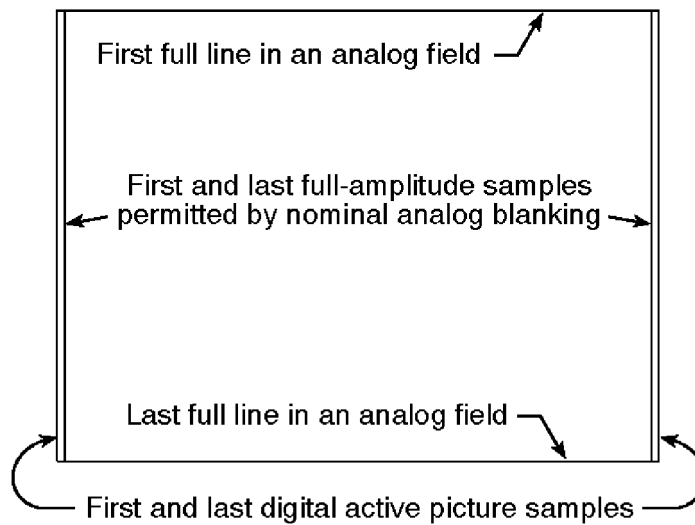

Figure 1-37: The Significance of the Active Picture Markers



Operating Information

Operating Information

This section duplicates material contained in the TSG601 User manual (Tektronix p/n 070-8910-00). The material is included here for your convenience. Please check the User manual whenever you need more information on any topic.

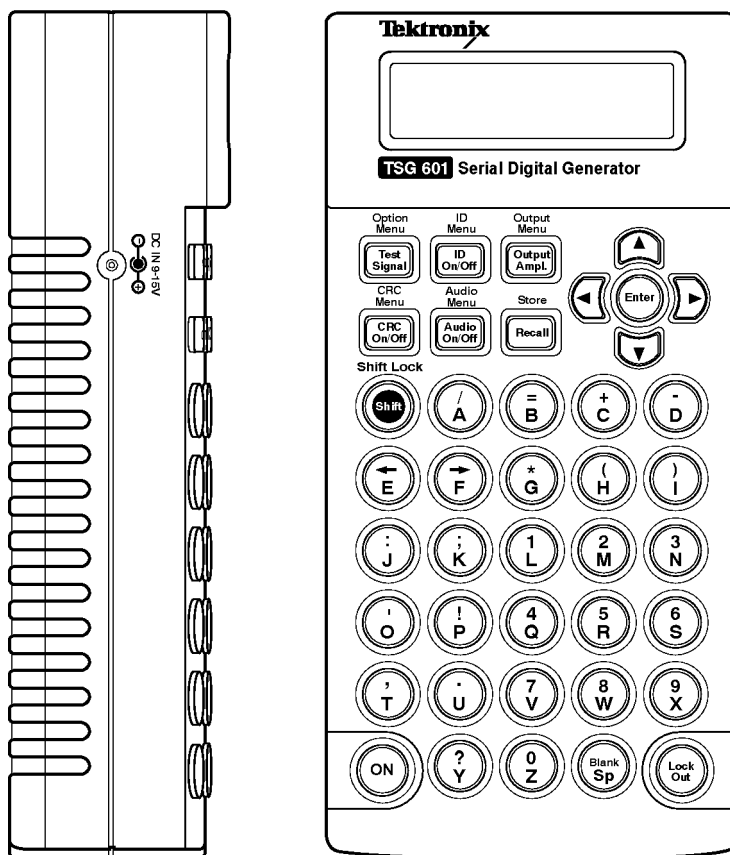

Powering the Instrument

The TSG601 is DC powered. You may power it with the standard AC adapter, the optional 9.6 V NiCad battery pack, eight standard AA batteries, or a “BP” type battery pack with the correct voltage and polarity. The external DC power connector is on the left side of the instrument (see the illustration above). Open the battery compartment by sliding the compartment door in the direction of the inscribed arrow until the door tabs line up with the slots in the case, then remove the door. When selecting a power source for your TSG601 please remember:

- Attempting to use an improper AC adapter can damage the instrument. USE AN APPROPRIATE DC POWER SOURCE ONLY: Voltage must be be-

tween 9 and 15 VDC; the center contact of the connector must be NEGATIVE polarity; and open-circuit voltage must not exceed 18 VDC. For best results, use the adapter supplied with the instrument.







- There is no need to remove the optional NiCad battery pack for recharging. The TSG601 will “trickle charge” the battery pack whenever the standard AC adapter is used. It can take up to 16 hours to fully charge the battery pack. *Note that charging will occur only if the adapter supplies at least 12 V; make sure that the adapter you use is appropriate for the local AC supply.*
- AA batteries are not included with the instrument; buy them locally. Rechargeable AA batteries may be used, but they are NOT recharged automatically. To recharge AA batteries, remove them from the instrument and use an appropriate battery charger. For safety, read and follow the battery charger instructions. Do NOT attempt to recharge standard alkaline batteries.
- After a minute with no key press, the display back light will be dimmed to conserve battery charge.
- To guard against battery discharge if you forget to turn the TSG601 off, enable Auto Power Down through the Diagnostic menu (see page 5-4).
- The TSG601 can sense low battery voltage. It will warn you when the charge is sufficient for approximately ten more minutes of operation. The instrument will shut itself down when the battery voltage becomes too low for reliable operation. See the Battery Hints in the Maintenance section of this manual (page 5-1).

The ON key toggles instrument power On and Off.



Keypad and Display Conventions

Please see the Instruction card (p/n 070-8909-00) supplied with the TSG601 for a “tour” of the keypad and an explanation of the display symbols. For your convenience, the following panels are taken from the card.

Display Symbols

-  = Auto power-down enabled (symbol “rotates”); use Diagnostic menu to disable; hold **Lock Out** down and press **ON** to enter the Diagnostic menu
-  = Improper signal path termination
-  = Shift (press **Shift** again to Shift Lock)
-  = Shift Lock (press **Shift** again to unlock)
-  = Lockout enabled (press **Lock Out** to unlock)
-  = Blank ID position; will not obscure test signal

Shift/Shift Lock

-  Only the next key press is shifted; shifted functions are shown in yellow
-  **Shift Lock**
 All following keys are shifted (until **Shift** is pressed again)

Keypad Lock Out

-  Toggles keypad Lock/Unlock; when locked, only **Lock Out** and **On** keys are “active” and display backlight is dimmed

Using your TSG 601

Here’s a list of what you can do with your TSG601. Simple instructions for each operation begin on the indicated page. For more information on any subject, see the User manual.

- Output serial video test signals (page 2-4).
 - Specify the peak-to-peak amplitude of the serial output, from 600 to 1000 mV (page 2-5).
 - Choose the video components (Y, C_r, C_b) to be included in the serial output (page 2-5).
 - Specify 8- or 10-bit video sample words (page 2-6).
- Embed CRC information (used for “Error Detection and Handling,” or EDH) in the output to detect or simulate errors originating in the serial data path (page 2-6).
- Add an ID message to the video signal, and place it where you want in the picture (page 2-7).
- Store up to eight ID messages for later use (pages 2-7, 2-9).

- Create a sequence of (up to four) stored ID messages that will cycle continuously in the output (page 2-8).
- Simulate the effect on your system of 50 m (164 ft.) of coaxial cable (page 2-9).
- Detect improper termination of the serial video signal path (page 2-9).
- Save all current instrument settings as a “Preset” for later recall (page 2-9).

Outputting Serial Video Test Signals

1. Connect the Serial Video Output of the instrument to your system. Use 75 Ω cable and be sure that the signal path is terminated properly.

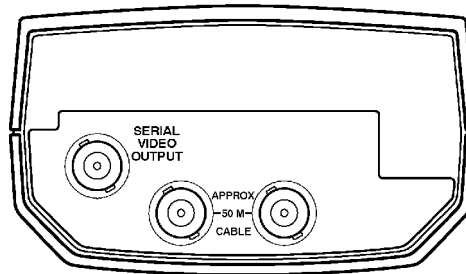

2. Power the TSG601 (page 2-1) and switch it on. By default, the instrument will begin with most settings that were in effect when it was switched off. Two exceptions: all video component channels will be ON (see page 2-5); and the output amplitude will be 800 mV.
3. Select the appropriate serial video standard (625/50 or 525/60) through the Diagnostic menu (pages 5-4, 5-6).
4. Return to normal operation by pressing the Test Signals key.
5. Select the desired test signal one of three ways:
 - Press the Test Signals key repeatedly until the name of the signal you want appears on the display. The signal will be output as soon as the name is visible. Or...
 - Use the ▲ and ▼ keys to scroll through the list of signals until you get to the desired signal. Or...
 - Press the appropriate letter key (A through P) to “Direct-Select” the signal. The available signals and their corresponding keys are listed in the following table.

Test Signal	Direct-Select Key
75% Color Bars	A
100% Color Bars	B
Pluge 1 (BBC 1)	C
Pluge 2 (BBC 2)	D
5-Step Staircase	E
Limit Ramp	F
Shallow Ramp	G
Modulated 5-Step	H
Modulated Pulse and Bar	I
60% Line Sweep with Markers	J
Bowtie	K
Convergence	L
Equalizer SDI Checkfield	M
PLL SDI Checkfield	N
Matrix SDI Checkfield	O
Active Picture Markers	P

Adjusting the Output Amplitude

1. Press the key marked “Output Ampl.”
2. Select the desired output level with the arrow keys. The ▲ / ▼ keys change the level to the next higher or lower 100 mV increment; ◀ / ▶ keys change it in 20 mV increments. Holding an arrow key down will continually increase or decrease the level until it reaches its minimum or maximum.
3. Press any rectangular key to exit the Output Amplitude Adjust function.

Controlling the Video Component (Y, C_r, C_b) Channels

1. Enter the Output menu (press **Shift**, then **Output Ampl.**) and press **ENTER** to reach “Channel Output Selection.” The display will look something like this:

```

Channel Y  Cb  Cr
Sel*  ON  ON  ON
    
```

2. Use the ◀ and ▶ keys to position the flashing underline cursor to the status (ON or OFF) of the channel you wish to change.
3. Toggle the status with the ▲ or ▼ key. The channel status will change instantly—you don't have to press **ENTER**.

NOTE. All three component channels default to ON whenever the TSG 601 is switched off and back on, regardless of prior "Channel Output" settings.

Specifying 8- or 10-bit Data Words

1. If necessary, enter the Output menu (press **Shift**, then **Output Ampl.**).
2. Scroll down to the "Video Data Word Length" item with the down arrow key and press **ENTER** to reach the word length selection display.
3. Use the ◀ or ▶ key to toggle between 8 and 10 bits; press **ENTER** to confirm the selection.
4. Press any rectangular key to exit the Output menu.

Specifying CRC Content of the Signal

1. Enter the CRC menu (press **Shift**, then **CRC On/Off**). The display will resemble the following illustration.

```

FFCRC  *  APCRC
ERR * ENTR  NORM
    
```

2. Use the ◀ / ▶ keys to select FFCRC (Full Field CRC) or APCRC (Active Picture CRC). Notice that the up/down symbol on the second display line will move to indicate the chosen type of CRC.
3. Use the ▲ / ▼ keys to select the type of CRC to be encoded into the output. The choices for the two types of CRCs are:
 - FFCRC — NORM or ERR (Error)
 - APCRC — NORM, ZERO, or ERR (Error)

See the User manual for an explanation of these options.

4. Once the desired CRC choices appear on the display, press **ENTER** to accept/invoke the selections.
5. Press any rectangular key to exit the CRC menu.
6. Toggle the inclusion of CRC data or errors on and off by pressing the “CRC On/Off” key. The CRC status will be reported on the second line of the display, alternating with the ID status.

Inserting ID Messages

- Toggle the ID message or cycle on and off with the “ID On/Off” key.

Editing ID Messages

1. Enter the ID menu (press **Shift**, then **ID On/Off**).
2. Press the **▼** key once to reach the “Edit ID #X” menu item. Note that the ID# first shown on the display always indicates the *current* (most recently recalled) ID.
3. Use the horizontal arrow keys to display the number of the ID you want to edit, then press **ENTER**.
4. Use the arrow keys to move the character cursor. Specify the character with the letter keys; press **Shift** to select symbols and numbers. The “Sp” key will enter a space, blacking out the underlying test pattern. The test pattern will show through a “Blank” (Shift-SP).
5. When you have made all the desired changes, press **ENTER** to save them. *(Note: pressing any rectangular key will abort the edit and exit the ID menu.)* If the ID message you started with in step 3 was “on-screen” when you began the edit, the new message will take its place. If not, and you wish to insert the new message, press the **▲** key to reach the “Recall ID #X” menu item, select the ID number with the horizontal arrow keys, and press **ENTER**.
6. As usual, press any rectangular key to exit the ID menu.

Positioning ID Messages

NOTE. Only the position of the currently displayed ID may be changed. If you wish to change the picture location of a message that is not displayed, you must first recall it through the ID menu or the Recall menu.

1. Enter the ID menu (press **Shift**, then **ID On/Off**), if necessary.
2. With the **▲** and **▼** keys, scroll to the “Position ID” menu item.
3. Press **ENTER**.
4. Use the arrow keys to move the message horizontally (H) and vertically (V) in the picture.
5. When the ID occupies the desired position, press **ENTER** to save the new location in memory and return to the ID menu. If you press any rectangular key *instead* of **ENTER**, the ID will remain in its new position—but will revert to the original location the next time it is recalled from memory.
6. As usual, press any rectangular key to exit the ID menu.

Setting up an ID Cycle

1. Edit and save the ID messages that you want to cycle (see “Editing ID messages,” page 2-7). Note the numbers of the IDs, and the order in which they should appear.
2. Scroll through the ID menu to reach the “ID Cycle Setup” item, then press **ENTER**. The display will resemble the following illustration.

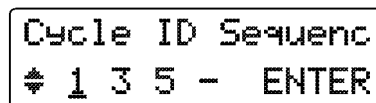

```
Cycle ID Sequenc
1 3 5 - ENTER
```

3. Use the **◀** / **▶** keys to move the underline cursor to one of the four sequence “time intervals.” The IDs will appear in the order that their numbers appear (from left to right) on the display.
4. Use the **▲** / **▼** keys to select the number of the ID to appear during each interval. Choose the hyphen (it’s below #1) to eliminate the interval. If you want a blank interval (that is, a time gap between ID messages), you must create an all-blank ID to put in that interval.
5. When the correct information is in all four time interval positions, press **ENTER** to confirm the cycle setup. (Press any rectangular key to abort the cycle edit.)
6. To set the duration of each cycle time interval, press the **▲** key to reach the “ID Cycle time” menu item. Use the horizontal arrow keys to select the duration between one and nine seconds. Press **ENTER** to confirm.
7. To replace the current ID with the ID cycle, scroll through the ID menu to the “ID Cycle OFF” selection. Press a horizontal arrow key to change the

selection to “ID Cycle ON,” then press **ENTER**. The cycle will appear in the picture if toggled on with the “ID On/Off” key.

Cable Simulation

- To simulate the addition of 50 meters of 75 Ω coaxial cable anywhere in your system, connect the TSG601 into the signal path with the two BNCs marked “APPROX 50M CABLE.” The connectors are interchangeable, and the circuit will simulate 50 m of Belden 8281 cable—which attenuates the signal by approximately 5.4 dB at 135 MHz—whether the TSG601 is switched on or off.

Detecting Incorrect Termination

- A special **I** symbol will “flash” in the upper right corner of the TSG601 display to indicate improper termination of the serial video signal path. The symbol is displayed whenever the instrument detects return loss below approximately 10 dB, which approximates termination impedance of less than 37.5 Ω or greater than 150 Ω .

Saving (Storing) Presets and IDs

1. Press **Shift** and then **Recall**. Note that the ID# first shown on the display always indicates the *current* (most recently recalled) ID.
2. Scroll through the “STORE ID” (#1 through #8) and “STO PRESET” (#1 through #4) locations with the left/right arrow keys. The first line of any ID message already stored in the # location will be shown in the bottom line of the display; use the **▼** key to see the second message line. Remember that storing the current settings or ID will overwrite the contents of the Preset or ID # location.
3. When the desired storage number is displayed, press **ENTER** to save the current ID or instrument settings. If you have stored an ID, it will replace the old # contents on the bottom display line.
4. Press any rectangular key to exit the Store function.

Note that IDs are normally saved—when they are edited—through the ID menu (see “Editing ID messages,” page 2-7). You may use the Recall/Store button, however, if you wish to copy the current ID to another memory location. Remember that the “current” ID is the last message recalled through the ID menu or **Recall**; the ID will be copied (and the previous contents of the ID# location overwritten) even when no message appears in the TSG601 output (ID=Off).

A preset includes all of the instrument settings in effect when the preset is saved, including the current output format, test signal, ID#, and cycle setup. Note that ID messages themselves are not stored. Thus, if a Preset “remembers” to display ID#4 (for example), the *latest* message in ID#4 will appear whenever that Preset is recalled. Remember, editing an ID message *can* have an affect on what you get when you recall a preset.

Recalling Presets and IDs

1. Press the **Recall** key. Note that the ID# first shown on the display always indicates the *current* (most recently recalled) ID.
2. Scroll through the “RECALL ID” (#1 through #8) and “RCL PRESET” (#1 through #4) locations with the ◀/ ▶ keys. The first line of an ID message will occupy the bottom line of the display; use the ▼ key to see the second line. For example, the “factory” ID#1 is “Tektronix TSG601 Serial Digital.” The display will first look like this:

```
Recall ID# 1◀▶  
Tektronix TSG601
```

Pressing the ▼ key will change it to this:

```
Recall ID# 1◀▶  
Serial Digital
```

You may find this feature useful if you save two or more IDs with the same first line of text.

3. When the desired storage number is displayed, press **ENTER** to recall the ID or Preset.
4. Press any rectangular key to exit the Recall menu.



Theory of Operation

Theory of Operation

This section contains a description of the TSG601 circuitry based on the block diagram shown in Figure 3-1.

Block Diagram Description

Overview The block diagram consists of the following major blocks:

Interface. The interface allows the user to control the operation of the instrument. The TSG601 has two standard methods of interfacing with the user. One method is input through the instrument keypad, and the other method is output through the liquid crystal display (LCD). The LCD consists of two lines with 16 characters per line. There is an alternate method of input through an internal RS-232 port, but this is used for manufacturing purposes only.

Controller. The TSG601 uses a microprocessor controller (A1U5) whose function is to control the operation of the instrument. It does so by polling the different inputs (keyboard or RS-232 port, battery low condition, and improper termination) and then responding accordingly.

Logic. The logic of the TSG601 is contained in a FPGA (A1U2). The logic in the FPGA can be blocked into three major groups:

- Extended memory access for the microprocessor to peripheral circuits

The FPGA decodes the upper address from the microprocessor and enables the appropriate circuits to read or write data from/to the microprocessor. Table 3-1 lists the memory addresses for the various circuits.

The eight lower address bits of the microprocessor are multiplexed on the same lines as the data (AD(0-7)). The FPGA latches these bits with the ASTB (address strobe) line and outputs them as A(0-7).

- Horizontal and Vertical Counters and Decoders

The H and V counter outputs, along with the output of the signal selection register, are used in addressing the signal PROM and SRAMs to obtain the appropriate signal information. The counter outputs are decoded for timing information to enable the FPGA to process the signal before outputting it to the serializer.

Table 3-1: Circuit Addresses

Hex Address	Circuit
7FFFF-0	Flash PROM (A1U4)
9FFFF-8000	Video Flash PROM (A1U6)
A7FFF-A0000	SRAM LSB (A1U26)
C7FFF-C0000	SRAM MSB (A1U21)
E0000	LCD Instruction Code
E0001	LCD Data Code
FFFFF-E0002	FPGA Registers (A1U2)

■ **Signal Processing Circuit**

The processing circuit receives the signal data (SD(0-9)) from the SRAMs, then adds secondary information before scrambling the signal. The secondary information consists of EAV (end of active video) and SAV (start of active video) timing, character ID (if any), and CRC ancillary data.

Memory. The TSG601 has two flash PROMs (128KX8) and two SRAMs (32KX8). The first flash PROM (A1U4) serves three functions: it contains the microprocessor code in hex addresses 0 to FFFF, NVRAM for the microprocessor in hex addresses 10000 to 17FFF, and the configuration data for the RAM-base FPGA in addresses 18000 to 1FFFF. The other flash PROM (A1U6) and the two SRAMs are used to generate signal information.

Output. The FPGA outputs a 10-bit parallel signal stream with a 27 MHz clock to a serializer (A1U11). The serializer multiplies the clock rate by 10 and outputs the data in a serial stream at 270 MHz. The output of the serializer passes through a buffer (A1U16) before being applied to the output connector. The buffer amplitude is variable and is controlled by the DAC output (SIG_LEVEL) of the microprocessor.

Termination Detector. The output signal line is monitored with a return-loss bridge and signal-strength meter IC to determine if the output is properly terminated.

Power Supply. The TSG601 uses a switching power supply to generate the +5 V supply. Input power can be supplied either through the DC input jack or by batteries mounted in the instrument's integral battery compartment.

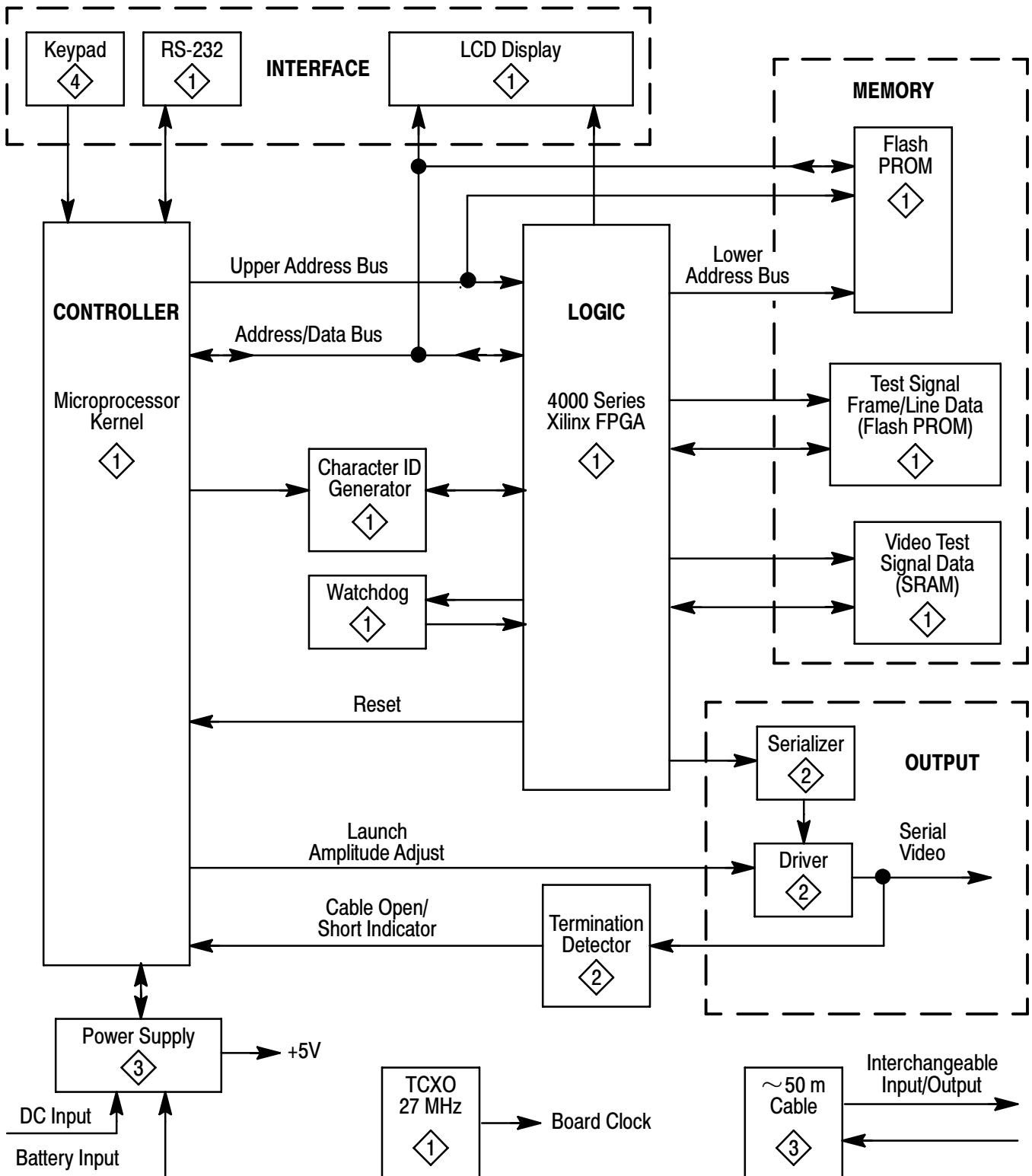

Figure 3-1: Block Diagram of the TSG601

Keypad

The keypad board (Assembly A2) is configured in a row and column format with the signal lines sent to the main board (Assembly A1) through A1J2. The row signal lines are inputs to the microprocessor (A1U5 ports 2X and 7X) and are pulled up to +5 V by A1R5. When a key is pressed, the $\approx 100 \Omega$ resistance of the key connects the row to the column of the pressed key.

The microprocessor (A1U5) drives the column lines low (0 V) one by one, reading the row lines to decode a key press. The column lines are normally driven high by the microprocessor (port 1X). When a column line is driven low, the other column lines are momentarily configured as inputs, leaving them floating. This is done to avoid having two outputs driving each other, with different levels, when two keys have been pressed. Only single key presses are decoded, with multiple key presses being ignored. The microprocessor polls the keypad board every 22 ms checking for key presses.

When the ON key is pressed, the regulated voltage (V_KEYBD) is connected to the ON_KEY control line. If the instrument is off, the ON_KEY line will turn the instrument on. When the instrument is on, the activation of the ON_KEY line will be detected by port 23 (/ONKEY_SAFE) of the microprocessor. The microprocessor will finish housekeeping details before shutting the instrument off using the PWR_DWN signal of port 07.

RS-232 Port

A portion of port 3X on A1U5 is used to run the RS-232 interface (A1J13). This interface is for manufacturing purposes only. A1U7 is the interface driver.

Microprocessor

The microprocessor (A1U5) is used to gather data and control the operation of the instrument based on this data. The microprocessor gathers data from several sources: the keypad, the internal RS-232 port, the battery voltage level, the output signal termination circuit, and the reset signal. The keypad and RS-232 inputs are discussed above.

The low battery condition is monitored on the BATT_LO line which is applied to port 70, which is an analog-to-digital converter input. When the battery voltage level (VIN) goes below a set threshold, the instrument will indicate low batteries on the LCD display. After going below another voltage threshold, the instrument shuts itself off. These voltage thresholds are dependent on the battery type and are listed in Table 3-2.

Table 3-2: Low Battery Voltage Thresholds

Battery Type	Low	Off
Alkaline	7.5 V	6.5 V
NiCad	9.3 V	8.6 V

The microprocessor exerts most of its control over the instrument through ports 4X, 5X, and 6X. Port 4X is a multiplex address (LSB) and data bus, while ports 5X and 6X handle the upper address bus and the read, write, and wait control lines. With the extended memory capabilities of these ports, the microprocessor can fetch instruction code from the flash PROM (A1U4), store and recall users presets in NVRAM (also in A1U4), control the logic circuits in the FPGA, and change the readout on the LCD display.

The microprocessor also controls other peripheral circuits through its I/O ports. The lower LSB of port 0X and P34 of port 3X are used to communicate with the Character ID chip (A1U23). P07 of port 0X shuts the power supply off when either a low battery condition is detected or an Off condition is selected from the keypad. P35 of port 3X is used to turn the backlight of the LCD on and off.

The microprocessor's digital-to-analog outputs (ANO0 and ANO1) are used to control the LCD display contrast level and the serial video output signal level respectively.

Startup Sequence

When the instrument is first turned on, the FPGA (A1U2) goes into its configuration routine. During this routine, the FPGA output signals LDC, INIT, and DONE are held low, while HDC is held high. The FPGA is a RAM-base IC and needs to read in the appropriate data in order to configure its internal logic. The FPGA uses the address and data buses connecting to and from the flash PROM (A1U4) to configure itself.

The FPGA starts at the MSB of A1U4 and decrements until all the configuration data is read (by the FPGA). During the configuration routine, the remaining I/Os of the FPGA are in a tri-state mode. The HDC signal is passed through an inverter (A1U22) and holds the microprocessor in the reset mode during this time. This causes the outputs of the microprocessor to be placed in a tri-state mode, removing contention from the address and data buses. After the configuration routine is completed, the FPGA is ready for operation. It releases the microprocessor to start setting up the instrument for operation by holding HDC low.

One of the tasks the microprocessor has during the instrument setup, is loading the fast signal data from the signal flash PROM (A1U6) into the SRAMs (A1U21 and A1U26). The microprocessor addresses the upper half of memory and reads the data out of A1U6, and then turns around and writes the information into the appropriate SRAM. Since the output of the PROM is only eight bits wide and the signal data is ten bits, the data is stored in the PROM with the lower eight bits at one location, and the two MSBs at the next address. The microprocessor loads the eight LSBs into A1U26 and the two MSBs into A1U21. During this time, the FPGA is outputting a serial video signal at a blanking level with EAV and SAV data. After the SRAMs are loaded, the microprocessor sets a flag in the FPGA that causes the instrument to enter into the operating sequence mode of operation, which is discussed below.

Operating Sequence

The normal operating sequence for the microprocessor is to poll the keypad every 22 ms for user inputs and to check for a low battery condition. The FPGA circuits are reading the signal data from the signal PROM and SRAMs, and processing the data to add character ID, SAV and EAV, and CRC ancillary data.

Once the signal is complete, it is output to the serializer (A1U11), scrambled to form the NRZI (non return to zero inverse) sequence using the following polynomials:

$$G1_{(x)} = x^9 + x^4 + 1$$

$$G2_{(x)} = x + 1$$

(NRZI is a polarity-insensitive video data scrambling scheme in which 0 = no change in logic, and 1 = a transition from one logic level to the other.)

Watchdog

The watchdog (A1U8) monitors the level of the +5 V supply, as well as the microprocessor and FPGA for a lockup condition. If the +5 V supply exceeds a $\pm 10\%$ tolerance, the watchdog will pull its reset line low until the tolerance condition is removed. When the reset line is pulled low, the FPGA is put into its reconfigure mode, which in turn resets the microprocessor.

The watchdog also must receive a pulse at least every 250 ms on the AWAKE line or it will reset the FPGA. The FPGA normally outputs the ASTB (address strobe) line from the microprocessor as the AWAKE signal. During a write or erase operation to the flash PROM (A1U4), the microprocessor is put into a WAIT mode by the FPGA (the WAIT line is pulled low for a period of time that may be longer than 250 ms). During the wait time, the FPGA outputs a field pulse to keep the watchdog from resetting. The field pulse is a square wave with a cycle time of 33.3 ms (40 ms PAL).

Serializer

The serializer (A1U11) receives 10-bit data words and a 27 MHz clock from the FPGA, and outputs a serial data stream at 270 MHz. A resonance tank of 540 MHz between pins 1 and 44 is used to convert the incoming 27 MHz clock to 270 MHz. The voltage level at A1TP1 should be near +3 V when the AFC is locked up. The serial data goes through the output driver (A1U16) which has a variable amplitude capability and complimentary outputs. The output level is controlled by the microprocessor through the SIG_LEVEL signal line.

Return-Loss Detector

The positive output of A1U11 goes through return-loss compensation before going to the output connector. The negative output goes through identical compensation before it is internally terminated. The two outputs are connected together at a summing point between A1R19 and A1R20. This summing point is used to determine proper termination of the output signal. If the output is not properly terminated in 75Ω , the summing point will activate the tank circuit made up of A1L3, A1C30, and circuit board capacitance. The tank circuit drives

the input to the signal strength meter (A1U13) which serves as a return-loss detector. A1U13 signals the microprocessor when the output return loss is out of specification, as set up by A1R31.

LCD Display

The microprocessor addresses the LCD display (Assembly A3) through the FPGA. The display is enabled through the LCDE control line. The LCD contrast is driven through A1Q4 from the microprocessor. The backlight is driven through A1Q2.

Power Supply

The TSG601 is DC powered either by batteries or by an AC adapter with a negative center lead orientation. When the adapter DC output is connected to A1J5, power is not drawn from the batteries. A1L7 and A1C7 act as an EMI regulator, and A1Q9 and A1VR1 protect the circuitry from a DC power adapter with a positive center lead. The +5 V regulator (A1U25) has very low quiescent power draw for battery life extension. It supplies the keyboard with power. When the ON key is pressed, the power is routed back to the power supply, using the flip-flop A1U1 to activate the switching supply.

Once A1U1 pin 6 has gone low, the switching regulator (A1U3) is turned on. Current output is enhanced by the driver made up of A1Q7, A1Q10, and A1Q8. The switching transformer (A1L1A) outputs +5 V. A1L1B is used to clean up the supply voltage for the analog circuitry.

The NiCad battery pack is charged through the circuit made up of A1Q12 and A1CR2 when the supply voltage is at least +10.5 V. At supply voltages less than that, the batteries will not charge.

The microprocessor shuts down the power supply using A1Q11 when a low battery state is detected.

50 m Cable Simulator

The 50 m cable simulator has been characterized to closely emulate 50 m of Belden 8281 coaxial cable. The simulator input and output are interchangeable.



Performance Verification and Adjustment Procedures

Performance Verification and Adjustment Procedures

This section consists of a detailed performance verification procedure to verify the operation of the TSG601, and an adjustment procedure to return the instrument to in-spec operation.

A performance verification “Checklist” appears on page 4-2.

Step-by-step performance verification procedures begin on page 4-2.

Step-by-step instructions for adjustment procedures begin on page 4-6.

Required Test Equipment

The following list of equipment represents the minimum required for the Performance Verification and Adjustment procedures. While alternate equipment may be used, it is not recommended. Alternate equipment must meet the minimum specifications for the listed equipment. Use of inadequate equipment may result in faulty measurements or calibration.

Table 4-1: Required Equipment

Item	Qty.	Requirements	Example
Oscilloscope	1	500 MHz bandwidth	Tektronix 11403A Digitizing Oscilloscope with 11A72 Plug-in
Spectrum Analyzer	1	Freq. Range: 325 MHz Sensitivity: up to 50 dB Internal tracking generator	Tektronix 2712, Option 04
RF Bridge	1	At least 46 dB return loss sensitivity, 50 kHz to 325 MHz	Wideband Engineering Part No. A57TGACR, and high-frequency terminator A56T75B
50 Ω BNC cable	1		Tektronix p/n 012-0057-00
75/50 Ω minimum loss attenuator, DC coupled	1		Tektronix p/n 011-0057-01 (required for oscilloscope plug-in with 50 Ω input; attenuates signal 2.3X)
75 Ω BNC termination	2	0.025% precision	Tektronix p/n 011-0102-01
50 Ω BNC termination	1		Tektronix p/n 011-0123-00
AC adapter	1		Std. TSG601 accessory
No. 1 Pozidrive®, 4” screw-driver	1		

Performance Verification Checklist

Use the following checklist if you are familiar with the operation of the TSG601 and video performance verification techniques.

NOTE. Allow a 20-minute warm-up for the TSG 601 and the instruments used for performance verification.

1. **Serial Digital Output Amplitude, Absolute Accuracy and DC Offset**
Absolute accuracy @ 800 mV setting: 800 ± 20 mV
DC offset: 0.0 ± 0.5 V
2. **Serial Digital Output Amplitude, Relative Accuracy**
Coarse increments: 100 ± 8 mV
Fine increments: 20 ± 8 mV
3. **Serial Digital Output Rise and Fall Times**
400–1000 ps @ 20% to 80% amplitude points
4. **Serial Digital Output Jitter**
Less than ± 360 ps
5. **Cable Simulator Return Loss**
At least 20 dB from 5 MHz to 270 MHz

Performance Verification Procedures

The order of these procedures has been chosen to minimize changes in equipment setup.

Preparation

Power up the test equipment and the TSG601. Allow a 20-minute warm-up.

Connect the TSG601 Serial Output to a 75/50 Ω minimum loss attenuator. Connect the other side of the pad to the 11403A through a 50 Ω cable.

Configure the 11403A as follows:

```
WAVEFORM MENU
Vertical Desc. . . . . (L1*2.3)
Horizontal Desc. . . . . Main @512 Points
Acquire Desc. . . . . Continuous
Vertical Mag: Wfm . . . . . 200 mV
Vertical Pos: Wfm . . . . . 0 V
Main Size . . . . . 1 ns
Main Pos . . . . . -4 ns
Impedance . . . . . 50  $\Omega$ 
```

Coupling DC
 BW Limit 1 GHz

NOTE. *Multiplying the vertical scale by 2.3 compensates for the attenuation due to the 75/50 Ω minimum loss attenuator.*

TRIGGER MENU

Trigger Main
 Source Description L1
 Level: M 0 V
 Time Holdoff: M 510 ns
 Mode Auto
 Coupling DC
 Slope “+”

MEASURE MENU

Amplitude (S)
 Rise (S) 20% to 80% (Left Limit = 10%, Right Limit = 95%)
 Fall (S) 20% to 80%
 Overshoot (S)
 Undershoot (S)
 MID (DC Level)

Procedures

1. Serial Digital Output, Absolute Amplitude Accuracy and DC Offset

Absolute amplitude accuracy specification: 800 mV \pm 20 mV

DC offset specification: 0 V \pm 0.5 V

- a. Press the **Output Ampl** button on the TSG601 and check for an 800 mV output amplitude.
- b. Use the 11403A to verify that the signal meets the above specifications.

2. Serial Digital Output Signal Amplitude, Relative Accuracy

Coarse increments specification: 100 \pm 8 mV

Fine increments specification: 20 \pm 8 mV

- a. Press the TSG601 \blacktriangledown key until 700 mV appears on the LCD.
- b. On the 11403A, verify that the signal amplitude is 700 \pm 8 mV.
- c. Press \blacktriangleright once so that 720 mV is displayed on the TSG601 LCD.
- d. On the 11403A, verify that the signal amplitude is 720 \pm 8 mV.
- e. Press \blacktriangle on the TSG601 until 900 mV appears on the LCD.

- f. On the 11403A, verify that the signal amplitude is 900 ± 8 mV.
- g. Press ◀ so that 880 mV is displayed on the TSG601 LCD.
- h. On the 11403A, verify that the signal amplitude is 880 ± 8 mV.

3. Serial Digital Output Rise and Fall Times

Specification: 400-1000 ps @ 20% to 80% amplitude points

- a. Verify, on the 11403A, that the rise time is between 400 and 1000 ps.
- b. Enter the 11403A TRIGGER menu and set the slope to “-”. Return to the MEASURE menu.
- c. Verify that the fall time is between 400 and 1000 ps.

4. Serial Digital Output Jitter

Specification: less than ± 360 ps

- a. Configure the 11403A as follows:

WAVEFORM MENU

Vertical Desc.	(L1*2.3)
Horizontal Desc.	Main @512 Points
Acquire Desc.	Continuous
Vert Mag: Wfm	200 mV
Vert Pos: Wfm	0 V
Main Size	10 μ s
Main Pos	0 s
Impedance	50 Ω
Coupling	DC
BW Limit	1 GHz

TRIGGER MENU

Trigger	Main
Source Description	L1
Level: M	0 V
Time Holdoff: M	510 ns
Mode	Auto
Coupling	DC
Slope	“+”

WINDOW MENU

Vertical Mag: Wfm	100 mV
Vertical Pos: Wfm	0 V
Window Size	500 ps/div
Window Position	40.001 μ s

CURSORS MENU

Vertical Bars

Cursor 1 40.00 μ sCursor 2 40.00 μ s Δ 498.4 ps

(cursors set so eye crossing is in the center)

- b. Set the TSG601 output amplitude to 800 mV.
- c. Verify that the eye crossing stays within the cursors.

5. Cable Simulator Return LossSpecification: ≥ 20 dB from 5 MHz to 270 MHz

- a. Connect a precision 50 Ω cable from the spectrum analyzer RF Input to the RF Output on the high-frequency RF Bridge.
- b. Connect a precision 50 Ω cable from the spectrum analyzer TG Output to the RF Input on the RF Bridge.
- c. Select Demod/TG on the spectrum analyzer. Turn on the Tracking Generator and set the Tracking Generator Fixed Level to 0.00 dBm.
- d. Set the spectrum analyzer Span/Div to 50 MHz, the Vertical Scale to 10 dB, Frequency range to 300 MHz, and the Resolution Bandwidth to 300 kHz.
- e. Set the spectrum analyzer Reference Level to the first major division down from the top on the analyzer display.
- f. Remove one of the cables from the RF Bridge.
- g. Set the spectrum analyzer Frequency Cursor to 250 MHz, and then set the Marker to 270 MHz.
- h. Reconnect the cable to the RF Bridge.
- i. Note the Reference Level Readout.
- j. In the Input Menu, adjust the spectrum analyzer External Attenuation Amplitude by the amount noted in the previous step. Note: The Reference Level Readout should now be 0.00 dBm.
- k. Connect the precision high-frequency terminator to the Device Under Test connector on the RF Bridge.
- l. Verify that the frequency response from 5 MHz to 270 MHz is ≥ 20 dB. This check verifies that you have a good terminator.
- m. Return the spectrum analyzer frequency marker to 270 MHz if it was moved.

- n. Remove the precision high-frequency terminator from the RF Bridge.
- o. Use a 75 Ω male-to-male BNC connector to attach the Device Under Test connector, on the RF Bridge, to one of the cable simulator BNCs. Terminate the remaining side of the loopthrough with a 75 Ω terminator.
- p. Verify that the Reference Level Readout on the spectrum analyzer is ≥ 25 dBm.

Adjustment Procedures

1. Termination Detection

- a. Use a No. 1 Pozidrive[®] screwdriver to remove the four screws found on the back of the instrument.

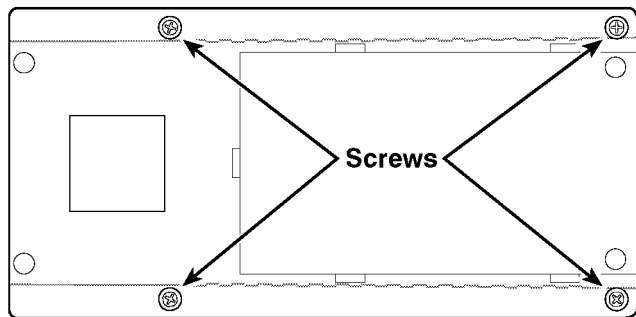

- b. Carefully pull the top and bottom halves of the instrument approximately one inch apart, then disconnect the ribbon cable from the top (keypad) half.
- c. Connect two 75 Ω BNC terminators together. Place the terminators on the TSG601 Serial Video Output.
- d. Connect the AC adapter and switch the TSG601 on.
- e. Place the instrument on its right-hand side (AC adapter plug pointing up), with the display end of the instrument farthest away from you; you will be making an adjustment on the main board while looking at the instrument's display.
- f. Adjust R31 counterclockwise until the flashing **T** symbol just appears.
- g. Replace the two 75 Ω terminators with a 50 Ω terminator. Verify that the **T** symbol does not appear.

- h.** To reassemble the instrument, reverse steps **b** and **a**. In step **b**, be sure to install the ribbon cable with the brown wire leading to pin 1 of J10.

2. Output Amplitude

Allow a minimum 20 minute warm-up for the TSG601 and the oscilloscope.

- a.** Configure the 11403A as follows:

WAVEFORM MENU

Vertical Desc.	(L1*2.3)
Horizontal Desc.	Main @512 Points
Acquire Desc.	Continuous
Vertical Mag: Wfm	200 mV
Vertical Pos: Wfm	0 V
Main Size	1 ns
Main Pos	-4 ns
Impedance	50 Ω
Coupling	DC
BW Limit	1 GHz

TRIGGER MENU

Trigger	Main
Source Description	L1
Level: M	0 V
Time Holdoff: M	510 ns
Mode	Auto
Coupling	DC
Slope	“+”

MEASURE MENU

Amplitude (S)
Rise (S) 20% to 80% (Left limit = 10% Right limit = 95%)
Fall (S) 20% to 80%
Overshoot (S)
Undershoot (S)
MID (DC Level)

- b.** Connect the TSG601 Serial Output to a 75/50 Ω minimum loss pad. Connect the other side of the pad to the 11403A through a 50 Ω cable.
- c.** On the TSG601 press and hold down the **Lock Out** button and then press the **ON** button. You will now be in the Diagnostic Menu.
- d.** Press and hold the down arrow until “SIGNAL AMPL” appears on the display, then press **ENTER**.
- e.** Use the left and right arrows to adjust the amplitude on the 11403A to 600 mV \pm 5 mV.

- f.** Press the up arrow. The display should now read “ADJ Signal Ampl. 800 mV.”
- g.** Use the left and right arrows to adjust the amplitude on the 11403A to $800 \text{ mV} \pm 5 \text{ mV}$.
- h.** Press the up arrow. The display should now read “ADJ Signal Ampl. 1000 mV.”
- i.** Use the left and right arrows to adjust the amplitude on the 11403A to $1 \text{ V} \pm 5 \text{ mV}$.
- j.** Press **ENTER** to store the new values in NVRAM.



Maintenance

Maintenance

Battery Hints

For optimal battery life and capacity, use the rechargeable NiCad battery pack (Tektronix p/n 119-4488-00) in full charge/discharge cycles. In other words, fully discharge the battery pack before recharging, and then charge the battery pack until fully charged, approximately 16 hours. A new battery pack will take a few charge/discharge cycles to reach full capacity.



WARNING. *Install or replace batteries only with the instrument switched OFF and the AC adapter disconnected.*

Replace the batteries only with standard AA batteries (1.2-1.5 V, nominal), or with a Tektronix rechargeable battery pack (p/n 119-4488-00).

Setting the Auto Power Down (page 5-5) and Battery Type (page 5-5) functions in the diagnostic menu also have an impact on battery life. The battery types are disposable (Alkaline) or rechargeable (NiCad). Setting the battery type changes the voltage thresholds for both the BATTERY LOW display message and low battery shut down.

The BATTERY LOW Message

The warning “BATTERY LOW” will appear on the second line of the TSG601 display when the battery voltage drops below a predetermined level. The level depends on the Battery Type set in the diagnostic menu (see page 5-5). The TSG will operate for approximately ten minutes after the message first appears. For best results, replace or recharge the batteries when you first see this warning.

Low Battery Shut Down

To prevent erratic operation at very low power levels, the TSG601 will shut itself down if the battery voltage drops below a second, lower threshold that also depends on the Battery Type setting.

Low battery shut down can happen with little or no warning if, for instance, the instrument has been left on by mistake with Auto Power Down disabled. In such cases, the TSG601 is likely to shut itself down almost immediately the next time you switch it on. If this happens:

- Install fresh batteries or operate the instrument with the AC adapter, and
- Confirm that the diagnostic menu Battery Type setting is appropriate.

The shut down threshold is higher for rechargeable batteries than for disposable. Therefore, you will receive a false BATTERY LOW message and may experience premature shut down if using Alkaline batteries when the Battery Type is

set to “rechargeable.” On the other hand, NiCad batteries may be damaged—they can lose their “rechargeability”—if they are discharged to the TSG601 threshold for disposable batteries. Be sure to select the correct Battery Type.

Preventive Maintenance

Under average conditions, the TSG601 should have preventive maintenance performed about every 2000 hours. This is approximately one year of operation. Preventive maintenance includes cleaning, visual inspection, a performance verification and, if necessary, adjustment. See Section 4 for performance verification and adjustment procedures.

Cleaning

Clean the instrument often enough to prevent dust and dirt from accumulating in or on it. Dirt can provide high-resistance electrical leakage paths between conductors or components in a humid environment.



CAUTION. *The TSG601 case is made of molded plastic. Do not allow water to get inside of any enclosed assembly or component. Do not clean any plastic materials with organic cleaning solvents, such as benzene, toluene, xylene, acetone, or similar compounds, because they may damage the plastic.*

Static-Sensitive Components

The TSG601 contains electrical components that are susceptible to damage from static discharge. Static voltages of 1 kV to 30 kV are common in unprotected environments.



CAUTION. *Static discharge can damage any semiconductor component in this instrument.*

Observe the following precautions to avoid static damage:

- Minimize handling of static-sensitive components.
- Transport and store static-sensitive components or assemblies in their original containers, on a metal rail, or on conductive foam. Label any package that contains static-sensitive assemblies or components.
- Discharge the static voltage from your body by wearing a wrist strap while handling these components. Servicing static-sensitive assemblies or components should only be performed at a static-free workstation by qualified personnel.

- Nothing capable of generating or holding a static charge should be allowed on the workstation surface.
- Keep the component leads shorted together whenever possible.
- Pick up components by the body, never by the leads.
- Do not slide the components over any surface.
- Avoid handling components in areas that have a floor or work surface covering capable of generating a static charge.
- Use a soldering iron that is connected to earth ground.
- Use only special antistatic, suction-type or wick-type desoldering tools.

Troubleshooting Aids

The following is miscellaneous information about schematics, circuit board illustrations, component numbering, and assembly numbering.

NOTE. *No repair should be attempted during the warranty period.*

Foldout Pages

The foldout pages at the back of the manual contain schematic diagrams and circuit board illustrations.

Diagrams

The circuit number and electrical value of each component is shown on the schematic diagrams. The first page in the Diagrams section explains the schematic symbols and notations found on the diagrams. The Replaceable Electrical Parts list gives a complete description of each component. Circuit boards and assemblies are shown with a heavy border, for identification. If the border does not completely encircle the schematic then that schematic only portrays part of the circuitry on that board or assembly. The name and assembly number of the circuit board are shown along the border as well as the serial number range that the schematic represents (if applicable).

NOTE. *Check for Change Information at the rear of the manual for inserts describing corrections and modifications to the instrument and manual.*

Circuit Board Illustrations

Electrical components, connectors, and test points are identified on circuit board illustrations located on the inside fold of the corresponding circuit diagram or the back of a preceding diagram.

Numbering

The circuit board assemblies are assigned assembly numbers starting with A1.

Circuit boards have been assigned an assembly number so that they may be ordered from Tektronix, Inc. They are as follows:

- A1 Main Board Assembly
- A2 Keypad Board Assembly
- A3 LCD Board Assembly

The part numbers for ordering these boards are listed first in the Replaceable Electrical Parts list (EPL), in Section 6.

The EPL is arranged in assembly-by-assembly order, as designated in ANSI Standard Y32.16-1975. Each component is assigned a circuit number, which is shown in the parts list by combining the assembly number and the circuit number.

EXAMPLE: R123 on assembly A2 would be listed in the EPL as A2R123.

In the EPL, assemblies are listed first, followed by circuit board-mounted parts in alphanumeric order. Parts mounted on the chassis are listed at the end of the EPL.

NOTE. *The complete part number shown in the parts list should be used when ordering replacement parts.*

Diagnostics

The Diagnostic Menu

To enter the diagnostic menu, hold the **Lock Out** button down while pressing the **ON** button. To exit the diagnostic menu and resume normal operation, press any of the rectangular buttons at the top of the keypad.

The diagnostic menu items are listed below. Use the up (▲) and down (▼) arrow keys to scroll up and down the list.

1 ▲ AUTO POWR DOWN disable ◀▶

1. Auto power down; use the left (◀) or right (▶) arrow key to toggle between enabled and disabled.

The Auto Power Down function shuts the TSG601 off when there has been no key press for approximately 10 minutes, to conserve battery charge. The Auto Power Down symbol (a rotating line) appears in the upper-right corner of the display when the function is enabled.

2 ⚡ Battery Type disposable ◀▶

2. Battery type; use the ◀ or ▶ key to toggle between disposable or rechargeable.

3 ⚡ Factory Reset Press ENTER

3. Factory Reset; press **Enter** to reset the instrument to the factory default settings. *WARNING: All user selections, ID messages, and Presets will be lost.*

4 ⚡ LCD Diag All On◀▶All Off

4. LCD Diagnostic; press the ◀ key to turn all segments on, and press the ▶ key to turn all segments off. Exit this diagnostic with the ▲ and ▼ keys as usual.

5 ⚡ LCD Contrast xx% ◀▶ ENTER

5. LCD Contrast; use the ◀ and ▶ keys to adjust display contrast to compensate for various viewing angles and ambient lighting.

6 ⚡ Signal Ampl. CAL Press ENTER

6. Signal Amplitude Calibrate; instructions for the use of this diagnostic function begin on page 4-7 (in the Verification and Adjustments section) of this manual.



CAUTION. Changing this setting will affect the serial video output amplitude and may give unexpected results. This utility should be used by Qualified Service Personnel ONLY.

7 **F**Format Select
Standard 625 ◀▶

7. Format Set; use the ◀ and ▶ keys to select between 625 (625 lines/50 Hz) and 525 (525 lines/60 Hz).

8 **S**Software Vx.x
Signals Vx.x

8. Software/Signal versions; note these numbers in any correspondence to Tektronix about your TSG601.

9 **K**KERNEL CHECK
SUM ENTER

9. Kernel Checksum; this information is used during manufacture and has no pertinence to operation or adjustment of the TSG601.

10 **X**XILINIX CHECK
SUM ENTER

10. Xilinx Checksum. This information is used during manufacture.

Corrective Maintenance

Corrective maintenance deals with obtaining replacement parts, torque specifications, and component replacement.

Obtaining Replacement Parts

Replacement parts are available from or through the local Tektronix, Inc., field office or representative.

When ordering parts be sure to include the following information in your order:

1. Instrument type (and option numbers, if any).
2. Instrument serial number.
3. Description of the part, as it appears in the electrical or mechanical parts list.
4. The Tektronix part number.

If a part that has been ordered is replaced with a new or improved part, the local Tektronix field office or representative will contact you concerning any change in the part number. After repair, the circuits may need readjustment.

Torque Specifications

Only #4 screws are used in the TSG601 to secure the case halves together. DO NOT USE MORE THAN 3 INCH POUNDS OF TORQUE ON THESE SCREWS.

Replacing Assemblies



WARNING. Disconnect the AC adapter and batteries before replacing any components.

Back Cover Removal/Replacement

Follow this procedure to remove and replace the back cover of the TSG601:

1. Remove the four screws securing the back cover to the front cover.

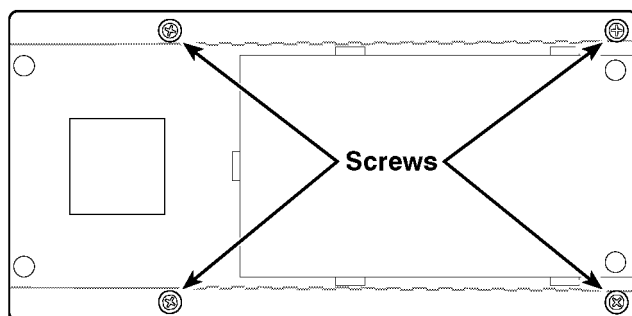

2. Gently separate the back cover about 1 inch from the instrument, taking care to not pull the rear panel (connector panel) away with it.
3. Disconnect the battery cable from J10. Make sure to pull on the connector housing to do this, not the wires. The back cover is now free and may be moved away from the instrument.
4. Replacement is the reverse of removal. Be sure that the *brown* wire of the battery cable assembly connects to pin 1 of J10.

Connector Panel Removal/Replacement

Follow this procedure to remove and replace the connector (“rear”) panel of the TSG601:

1. With the back cover removed, disconnect the cable from J1 on the connector panel. Again, pull on the connector housing, not on the wires.
2. Slide the assembly up away from the front panel.
3. Replacement is the reverse of removal.

Main Board and LCD Removal/Replacement

Follow this procedure to remove and replace the Main board and LCD of the TSG601:

1. After removing the connector panel, use a pair of needle-nose pliers to gently pull the J2 housing up away from the instrument. Pull straight up, lifting the Main board at the same time. Do NOT bend the connector housing.
2. When J2 pulls free, lift the Main board and the LCD display away from the case.
3. To separate the Main board and LCD display module, disconnect the LCD display cable from J6, and gently pull the two assemblies apart at J1. The rubber board spacers should remain attached to the LCD display.
4. Replacement is the reverse of removal.

Keypad Removal

Follow this procedure to remove the TSG601 keypad:

1. Once the Main board is out of the way, lift the plastic spacer board out of the instrument. This is held in place only by a friction fit.
2. Lift the Keypad board out of the TSG601. This too is held in place by a friction fit.
3. Peel the rubber keypad out of the front panel.

Keypad Replacement

Once the keypad has been removed from the front panel, follow this procedure to replace the TSG601 keypad:

1. Place the Keypad board with the pins of the connector towards the workbench.
2. Place the rubber keypad on top of the Keypad board, positioning it so that the ON button is in the corner closest the connector.
3. Adjust the rubber keypad so that the fingers on its back side fit through the corresponding holes in the Keypad board.
4. Holding the keypad and Keypad board with the buttons up, slide the front case onto them, aligning the rubber buttons with the holes for them in the front case as you do so. The Keypad board is a friction fit in the front case half, so you must apply some slight pressure to fully seat the assemblies into the case.
5. Place the assembled front case and keypad face down on the workbench and press the plastic spacer board into place. Align the cutout in the spacer board with the connector. The plastic fingers will be facing up.
6. Replace all assemblies by reversing the above procedures, as necessary.



Replaceable Electrical Parts

Replaceable Electrical Parts

This section contains a list of the components that are replaceable for the TSG 601. Use this list to identify and order replacement parts. There is a separate Replaceable Electrical Parts list for each instrument.

Parts Ordering Information

Replacement parts are available from or through your local Tektronix, Inc., Field Office or representative.

Changes to Tektronix instruments are sometimes made to accommodate improved components as they become available and to give you the benefit of the latest circuit improvements. Therefore, when ordering parts, it is important to include the following information in your order.

- Part number
- Instrument type or model number
- Instrument serial number
- Instrument modification number, if applicable

If a part you have ordered has been replaced with a new or improved part, your local Tektronix, Inc., Field Office or representative will contact you concerning any change in part number.

Change information, if any, is located at the rear of this manual.

Using the Replaceable Electrical Parts List

The tabular information in the Replaceable Electrical Parts list is arranged for quick retrieval. Understanding the structure and features of the list will help you find all of the information you need for ordering replaceable parts.

Cross Index-Mfr. Code Number to Manufacturer

The Mfg. Code Number to Manufacturer Cross Index for the electrical parts list is located immediately after this page. The cross index provides codes, names, and addresses of manufacturers of components listed in the electrical parts list.

Abbreviations

Abbreviations conform to American National Standards Institute (ANSI) standard Y1.1.

List of Assemblies

A list of assemblies can be found at the beginning of the electrical parts list. The assemblies are listed in numerical order. When the complete component number of a part is known, this list will identify the assembly in which the part is located.

Column Descriptions

Component No. (Column 1)

The component circuit number appears on the diagrams and circuit board illustrations, located in the diagrams section. Assembly numbers are also marked on each diagram and circuit board illustration, in the Diagram section and on the mechanical exploded views, in the mechanical parts list. The component number is obtained by adding the assembly number prefix to the circuit number.

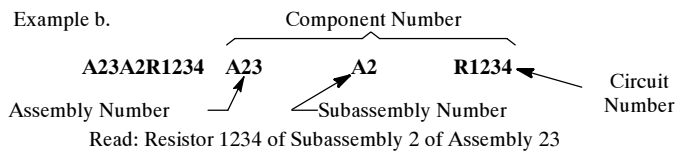
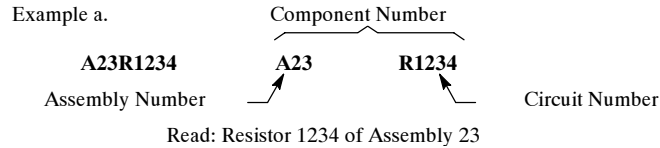

The electrical parts list is arranged by assemblies in numerical sequence (A1, with its subassemblies and parts, precedes A2, with its subassemblies and parts).

Mechanical subparts to the circuit boards are listed in the electrical parts list. These mechanical subparts are listed with their associated electrical part (for example, fuse holder follows fuse).

Chassis-mounted parts and cable assemblies have no assembly number prefix and are located at the end of the electrical parts list.

Tektronix Part No. (Column 2)

Indicates part number to be used when ordering replacement part from Tektronix.

Serial/Assembly No. (Column 3 and 4)

Column three (3) indicates the serial or assembly number at which the part was first used. Column four (4) indicates the serial or assembly number at which the part was removed. No serial or assembly number entered indicates part is good for all serial numbers.

Name and Description (Column 5)

An item name is separated from the description by a colon (:). Because of space limitations, an item name may sometimes appear as incomplete. Use the U.S. Federal Catalog handbook H6-1 for further item name identification.

The mechanical subparts are shown as *ATTACHED PARTS* / *END ATTACHED PARTS* or *MOUNTING PARTS* / *END MOUNTING PARTS* in column five (5).

Mfr. Code (Column 6)

Indicates the code number of the actual manufacturer of the part. (Code to name and address cross reference can be found immediately after this page.)

Mfr. Part No. (Column 7)

Indicates actual manufacturer's part number.

Replaceable Electrical Parts

Component Number	Tektronix Part Number	Serial / Assembly Number Effective	Discontinued	Name & Description
A1	671-2967-00		B019999	CIRCUIT BOARD:MAIN
	671-2967-02	B020000	B020298	CIRCUIT BOARD:MAIN
	671-2967-03	B020299	B030373	CIRCUIT BOARD:MAIN
	671-2967-04	B030374	B040554	CIRCUIT BOARD:MAIN
	671-2967-05	B040555	B040679	CIRCUIT BOARD:MAIN
	671-2967-06	B040680	B040705	CIRCUIT BOARD:MAIN
	671-2967-07	B040706	B041213	CIRCUIT BOARD:MAIN
	671-2967-08			CIRCUIT BOARD:MAIN
	671-2967-09	B041214	B052014	CIRCUIT BOARD:MAIN
	671-2967-10	B052015	B052099	CIRCUIT BOARD:MAIN
	671-2967-11	B052100		CIRCUIT BOARD:MAIN
A2	671-2586-01			CIRCUIT BD ASSY:KEYBOARD
A3	119-4506-00		B040554	DISPLAY,MODULE:,LCD;16 CHARACTERS X 2 LINES,5 X 7 DOT MATRIX,TRANSFLECTIVE,YEL/GRN LED
	119-5566-00	B040555	B041212	DISPLAY MODULE; LCD;16 CHARACTERS X 2 LINES,5 X 7 DOT MATRIX,TRANSFLECTIVE,YEL/GRN LED BACKLIGHT,WIDE TEMP RANGE
	119-5566-01	B041213	B052014	DISPLAY MODULE; LCD;16 CHARACTERS X 2 LINES,5 X 7 DOT MATRIX,TRANSFLECTIVE,YEL/GRN LED BACKLIGHT,WIDE TEMP RANGE
	119-5566-02	B052015		DISPLAY MODULE; LCD;16 CHARACTERS X 2 LINES,5 X 7 DOT MATRIX,TRANSFLECTIVE,YEL/GRN LED BACKLIGHT,WIDE TEMP RANGE
A4	671-3227-00			CKT BD ASSY:REAR PANEL BOARD
A1	671-2967-00		B019999	CIRCUIT BOARD:MAIN
	671-2967-02	B020000	B020298	CIRCUIT BOARD:MAIN
	671-2967-03	B020299	B030373	CIRCUIT BOARD:MAIN
	671-2967-04	B030374	B040554	CIRCUIT BOARD:MAIN
	671-2967-05	B040555	B040679	CIRCUIT BOARD:MAIN
	671-2967-06	B040680	B040705	CIRCUIT BOARD:MAIN
	671-2967-07	B040706	B041213	CIRCUIT BOARD:MAIN
	671-2967-08			CIRCUIT BOARD:MAIN
	671-2967-09	B041214	B052014	CIRCUIT BOARD:MAIN
	671-2967-10	B052015	B052099	CIRCUIT BOARD:MAIN
	671-2967-11	B052100		CIRCUIT BOARD:MAIN
A1C1	283-5114-00			CAP,FXD,CER:MLC;0.1UF,10%,50V,X7R,1206
A1C2	290-5050-00			CAP,FXD,AL:47UF,20%,35V,6 H X 8 DIA MM;LOW IMP,SMD
A1C3	283-5114-00			CAP,FXD,CER:MLC;0.1UF,10%,50V,X7R,1206
A1C4	283-5282-00			CAP,FXD,CER:MLC;2.2UF,+80-20%,16V,Y5V,0.120 X 0.060
A1C5	283-5282-00			CAP,FXD,CER:MLC;2.2UF,+80-20%,16V,Y5V,0.120 X 0.060
A1C6	283-5282-00			CAP,FXD,CER:MLC;2.2UF,+80-20%,16V,Y5V,0.120 X 0.060
A1C7	283-5114-00			CAP,FXD,CER:MLC;0.1UF,10%,50V,X7R,1206
A1C8	283-5267-00			CAP,FXD,CER:MLC;1UF,+80%-20%,25V,Y5V,1206
A1C9	283-5350-00	671-2967-11		CAP,FXD,CERAMIC; MLC;1000PF,10%,100V,X7R ,TIN PLATE;0603/1608(EIAJ),SMD
A1C12	283-5283-00		671-2967-05	CAP,FXD,CER:MLC;1.5PF,+/- .25PF,100V,NPO,.120X.060
	283-5006-00	671-2967-06		CAP;5PF,+/-0.25PF,50V,NPO,1206;SMD,8MM T&R
A1C14	283-5267-00			CAP,FXD,CER:MLC;1UF,+80%-20%,25V,Y5V,1206
A1C15	283-5283-00		671-2967-05	CAP,FXD,CER:MLC;1.5PF,+/- .25PF,100V,NPO,.120X.060
	283-5006-00	671-2967-06		CAP;5PF,+/-0.25PF,50V,NPO,1206;SMD,8MM T&R
A1C16	283-5002-00		671-2967-10	CAP,FXD,CER:MLC;1000PF,10%,50V,NPO,1206
A1C17	283-5113-00		671-2967-02	CAP,FXD,CER:MLC;0.047UF,10%,50V,X7R,1206
	283-5203-00	671-2967-03	671-2967-10	CAP,FXD,CERAMIC; MLC;1000PF,10%,100V,X7R ,TIN PLATE;1206/3216
A1C18	283-5279-00		671-2967-02	CAP,FXD,CER:MLC;0.47UF,10%,50V,X7R,.180X.250
	283-0191-00	671-2967-03	671-2967-05	CAP,FXD,CERAMIC; MLC;0.022UF,20%,50V,X7R;RADIAL SQUARE
	283-5202-00	671-2967-06	671-2967-10	CAP,FXD,CERAMIC; MLC;0.022UF,20%,50V,X7R;RADIAL SQUARE
A1C19	283-5003-00		671-2967-10	CAP,FXD,CER:MLC;0.01UF,10%,50V,X7R,1206
A1C26	283-5003-00			CAP,FXD,CER:MLC;0.01UF,10%,50V,X7R,1206
A1C27	283-5200-00			CAP,FXD,CER DI:0.47UF,+80-20%,50V
A1C28	283-5200-00			CAP,FXD,CER DI:0.47UF,+80-20%,50V
A1C29	283-5114-00			CAP,FXD,CER:MLC;0.1UF,10%,50V,X7R,1206

Replaceable Electrical Parts

Component Number	Tektronix Part Number	Serial / Assembly Number		Name & Description
		Effective	Discontinued	
A1C30	283-5114-00			CAP,FXD,CER:MLC;0.1UF,10%,50V,X7R,1206
A1C31	283-5114-00			CAP,FXD,CER:MLC;0.1UF,10%,50V,X7R,1206
A1C33	283-5114-00			CAP,FXD,CER:MLC;0.1UF,10%,50V,X7R,1206
A1C34	283-5003-00		671-2967-10	CAP,FXD,CER:MLC;0.01UF,10%,50V,X7R,1206
A1C36	283-5114-00			CAP,FXD,CER:MLC;0.1UF,10%,50V,X7R,1206
A1C37	283-5114-00			CAP,FXD,CER:MLC;0.1UF,10%,50V,X7R,1206
A1C38	283-5114-00			CAP,FXD,CER:MLC;0.1UF,10%,50V,X7R,1206
A1C39	283-5114-00			CAP,FXD,CER:MLC;0.1UF,10%,50V,X7R,1206
A1C40	283-5203-00			CAP,FXD,CER:MLC;1000PF,10%,100V,X7R,1206
A1C41	283-5203-00			CAP,FXD,CER:MLC;1000PF,10%,100V,X7R,1206
A1C42	283-5203-00			CAP,FXD,CER:MLC;1000PF,10%,100V,X7R,1206
A1C43	283-5114-00			CAP,FXD,CER:MLC;0.1UF,10%,50V,X7R,1206
A1C44	283-5114-00			CAP,FXD,CER:MLC;0.1UF,10%,50V,X7R,1206
A1C45	283-5114-00			CAP,FXD,CER:MLC;0.1UF,10%,50V,X7R,1206
A1C46	283-5114-00			CAP,FXD,CER:MLC;0.1UF,10%,50V,X7R,1206
A1C47	283-5114-00			CAP,FXD,CER:MLC;0.1UF,10%,50V,X7R,1206
A1C48	283-5114-00			CAP,FXD,CER:MLC;0.1UF,10%,50V,X7R,1206
A1C49	283-5114-00			CAP,FXD,CER:MLC;0.1UF,10%,50V,X7R,1206
A1C50	283-5114-00			CAP,FXD,CER:MLC;0.1UF,10%,50V,X7R,1206
A1C51	283-5114-00			CAP,FXD,CER:MLC;0.1UF,10%,50V,X7R,1206
A1C52	283-5114-00			CAP,FXD,CER:MLC;0.1UF,10%,50V,X7R,1206
A1C53	283-5114-00			CAP,FXD,CER:MLC;0.1UF,10%,50V,X7R,1206
A1C54	283-5114-00			CAP,FXD,CER:MLC;0.1UF,10%,50V,X7R,1206
A1C56	290-0943-00			CAP,FXD,ALUM:47UF,+50-20%,25V,6 X 11MM
A1C57	290-5034-01			CAP,FXD,ALUM:33UF,20%,10V,5.7MM(0.224)
A1C58	283-5114-00		671-2967-10	CAP,FXD,CER:MLC;0.1UF,10%,50V,X7R,1206
	283-5353-00	671-2967-11		CAP,FXD,CERAMIC; MLC;0.1UF,20%,16V,X7R ,TIN PLATE;0603/1608(EIAJ),SMD
A1C59	283-5203-00		671-2967-10	CAP,FXD,CER:MLC;1000PF,10%,100V,X7R,1206
	283-5350-00	671-2967-11		CAP,FXD,CERAMIC; MLC;1000PF,10%,100V,X7R ,TIN PLATE;0603/1608(EIAJ),SMD
A1C60	283-5203-00		671-2967-10	CAP,FXD,CER:MLC;1000PF,10%,100V,X7R,1206
	283-5350-00	671-2967-11		CAP,FXD,CERAMIC; MLC;0.1UF,20%,16V,X7R ,TIN PLATE;0603/1608(EIAJ),SMD
A1C61	283-5114-00		671-2967-10	CAP,FXD,CER:MLC;0.1UF,10%,50V,X7R,1206
	283-5353-00	671-2967-11		CAP,FXD,CERAMIC; MLC;0.1UF,20%,16V,X7R ,TIN PLATE;0603/1608(EIAJ),SMD
A1C62	283-5114-00		671-2967-10	CAP,FXD,CER:MLC;0.1UF,10%,50V,X7R,1206
	283-5353-00	671-2967-11		CAP,FXD,CERAMIC; MLC;0.1UF,20%,16V,X7R ,TIN PLATE;0603/1608(EIAJ),SMD
A1C63	283-5114-00			CAP,FXD,CER:MLC;0.1UF,10%,50V,X7R,1206
A1C64	283-5114-00			CAP,FXD,CER:MLC;0.1UF,10%,50V,X7R,1206
A1C65	283-5114-00			CAP,FXD,CER:MLC;0.1UF,10%,50V,X7R,1206
A1C66	283-5114-00			CAP,FXD,CER:MLC;0.1UF,10%,50V,X7R,1206
A1C67	283-5049-00			CAP,FXD,CER:MLC;180PF,5%,50V,NPO,1206
A1C68	283-5114-00			CAP,FXD,CER:MLC;0.1UF,10%,50V,X7R,1206
A1C69	283-5203-00			CAP,FXD,CER:MLC;1000PF,10%,100V,X7R,1206
A1C71	283-5203-00			CAP,FXD,CER:MLC;1000PF,10%,100V,X7R,1206
A1C72	283-5114-00			CAP,FXD,CER:MLC;0.1UF,10%,50V,X7R,1206
A1C73	283-5003-00			CAP,FXD,CER:MLC;0.01UF,10%,50V,X7R,1206
A1C74	283-5002-00			CAP,FXD,CER:MLC;1000PF,10%,50V,NPO,1206
A1C75	283-5113-00			CAP,FXD,CER:MLC;0.047UF,10%,50V,X7R,1206
A1C76	283-5049-00			CAP,FXD,CER:MLC;180PF,5%,50V,NPO,1206
A1C77	283-5003-00			CAP,FXD,CER:MLC;0.01UF,10%,50V,X7R,1206
A1C78	283-5049-00			CAP,FXD,CER:MLC;180PF,5%,50V,NPO,1206
A1C79	283-5049-00			CAP,FXD,CER:MLC;180PF,5%,50V,NPO,1206
A1C81	283-5114-00			CAP,FXD,CER:MLC;0.1UF,10%,50V,X7R,1206
A1C82	290-5034-01			CAP,FXD,ALUM:33UF,20%,10V,5.7MM(0.224)
A1C83	283-5187-00			CAP,FXD,CER:MLC;15PF,5%,100V,NPO,1206
A1C84	283-5187-00			CAP,FXD,CER:MLC;15PF,5%,100V,NPO,1206
A1C85	283-5188-00			CAP,FXD,CER:MLC;100PF,5%,100V,NPO,1206
A1C87	283-5188-00			CAP,FXD,CER:MLC;100PF,5%,100V,NPO,1206
A1C88	283-5114-00			CAP,FXD,CER:MLC;0.1UF,10%,50V,X7R,1206

Replaceable Electrical Parts

Component Number	Tektronix Part Number	Serial / Assembly Number		Name & Description
		Effective	Discontinued	
A1C89	283-5114-00			CAP,FXD,CER:MLC;0.1UF,10%,50V,X7R,1206
A1C90	283-5203-00			CAP,FXD,CER:MLC;1000PF,10%,100V,X7R,1206
A1C91	283-5114-00			CAP,FXD,CER:MLC;0.1UF,10%,50V,X7R,1206
A1C92	283-5203-00			CAP,FXD,CER:MLC;1000PF,10%,100V,X7R,1206
A1C93	283-5203-00			CAP,FXD,CER:MLC;1000PF,10%,100V,X7R,1206
A1C98	283-5005-00		671-2967-10	CAP,FXD,CER:MLC;4PF,+/-0.25PF,50V,NPO,1206
A1C99	283-5005-00			CAP,FXD,CER:MLC;4PF,+/-0.25PF,50V,NPO,1206
A1C100	290-0943-00			CAP,FXD,ALUM:47UF,+50-20%,25V,6 X 11MM
A1C101	283-5267-00			CAP,FXD,CER:MLC;1UF,+80%-20%,25V,Y5V,1206
A1C102	283-5267-00			CAP,FXD,CER:MLC;1UF,+80%-20%,25V,Y5V,1206
A1C103	283-5282-00			CAP,FXD,CER:MLC;2.2UF,+80-20%,16V,Y5V,0.120 X 0.060
A1C105	283-5267-00			CAP,FXD,CER:MLC;1UF,+80%-20%,25V,Y5V,1206
A1C106	283-5188-00			CAP,FXD,CER:MLC;100PF,5%,100V,NPO,1206
A1C107	283-5195-00		671-2967-01	CAP,FXD,CER:MLC;10PF,5%,100V,NPO,1206
A1C108	283-5114-00			CAP,FXD,CER:MLC;0.1UF,10%,50V,X7R,1206
A1C109	283-5203-00			CAP,FXD,CER:MLC;1000PF,10%,100V,X7R,1206
A1C110	283-5114-00			CAP,FXD,CER:MLC;0.1UF,10%,50V,X7R,1206
A1C111	290-1322-00			CAP,FXD,ALUM:470UF,20%,16V,ESR = 0.095OHM(20C,100KHZ),10 X 12.5MM,LS=5MM
A1C112	283-5114-00			CAP,FXD,CER:MLC;0.1UF,10%,50V,X7R,1206
A1C113	283-5114-00			CAP,FXD,CER:MLC;0.1UF,10%,50V,X7R,1206
A1C114	283-0175-00	671-2967-02	671-2967-05	CAP,FXD,CERAMIC;MLC;10PF,5%,200V
	283-5195-00	671-2967-06	671-2967-10	CAP,FXD,CERAMIC;MLC;10PF,5%,200V
	283-5334-00	671-2967-11		CAP,FXD,CERAMIC;MLC;10PF,5%,100V,COG/NPO,TIN PLATE;0603/1608(JEITA),SMD,8MM
A1C115	283-0175-00	671-2967-06		Cap FXD,LC; 1.0 uF -20 +80, 25 V, 0.120 X0.060, Y5V,SMD, 8 mm,
A1CR1	152-5027-00			DIODE,RECT:SCHTKY;40V,1A
A1CR2	152-5018-00			DIODE,SIG:,ULTRA FAST;100V,0.74VF,4NS,2.0PF,SER-PAIR
A1CR3	152-5027-00			DIODE,RECT:SCHTKY;40V,1A
	152-0836-00		671-2967-10	DIODE,RECT;SCHOTTKY;40V,1A,25A IFSM,600MV AT 1A,1MA IR AT 40V,AXIAL LEAD
	152-5086-00	671-2967-11		DIODE,RECT;ULTRA FAST;600V,1A,50NS;MURS160,DO-214AA/SMB
A1CR4	152-5086-00			DIODE,RECT;ULTRA FAST;600V,1A,50NS
A1CR5	152-0843-00			DIODE,SIG:SCHTKY;SER-PAIR,20V,410MV,1.3PF
A1CR6	152-5045-00			DIODE,SIG:SCHTKY;20V,1.2PF,24 OHM
A1E1	108-5084-00			COIL,RF:FERRITE CHIP BEAD,52 OHM +/-25%@100MHZ,DCR 0.3 OHM,IMAX 400 MA,8MM T&R
A1E2	108-5084-00			COIL,RF:FERRITE CHIP BEAD,52 OHM +/-25%@100MHZ,DCR 0.3 OHM,IMAX 400 MA,8MM T&R
A1F1	159-0363-00		671-2967-00	FUSE,WIRE LEAD:4A,125V,FAST BLOW,ULREC,CSACERT,;
	159-0378-00	671-2967-01		FUSE,WIRE LEAD; 2.0A,125V,1 SEC MIN - 60 SEC MAX AT 200%,SLOW BLOW
A1J1	131-5542-01			CONN,BOX:PCB,BTM ENTRY;FEM,STR,2 X 7,0.1 CTR,0.235 H X 0.125 TAIL,30 GOLD,SLDR MASKPOSTS,DUAL ENTRY
A1J2	131-5543-01			CONN,BOX:PCB,BTM ENTRY;FEM,STR,2 X 10,0.1 CTR,0.23 H X 0.125 TAIL,30 GLD,SLDR-MASK POST,DUAL ENTRY
A1J5	131-5527-00			JACK,PWR DC:PCB;MALE,RTANG,2MM PIN,11MMH(0.433) X 3.5MM(0.137) TAIL,9MM(0.354) W,TIN,W/SW,DC PWR JACK
A1J6	131-4794-00			CONN,HDR::PCB;MALE,STR,1 X 2,0.1 CTR,0.235
A1J8	131-0391-00			CONN,RF JACK:SMB;50 OHM,STR,PCB,GOLD/GOLD,0.293 H X 0.155 TAIL,3/0.045 SQ TAIL 0.038DIA CTRCOND,0.2 SQ PCB,0.312 HEX
A1J10	131-5240-00			CONN,HDR:PCB;MALE,STR,1 X 5,0.1 CTR,0.230MLG X 0.120 TAIL,30 GOLD
A1J13	131-5267-00		671-2967-09	CONN,HDR:PCB;MALE,STR,2 X 40,0.1 CTR,0.235
A1J15	131-4794-00			CONN,HDR::PCB;MALE,STR,1 X 2,0.1 CTR,0.235
A1J21	131-0391-00			CONN,RF JACK:SMB;50 OHM,STR,PCB,GOLD/GOLD,0.293 H X 0.155 TAIL,3/0.045 SQ TAIL 0.038DIA CTRCOND,0.2 SQ PCB,0.312 HEX
A1L1	108-1545-00			INDUCTOR,DUAL:TOROID,314UH,10%,157UH AT 1ADCMAX,0.25 OHMS,15 X 12MM
A1L3	108-0598-00			COIL,RF:FIXED,200UH
A1L7	120-1939-00			TRANSFORMER:Z-92266
A1Q1	151-5066-00			TRANSISTOR,SIG:MOS,N-CH;60V,0.115A,7.5 OHM
A1Q2	151-5066-00			TRANSISTOR,SIG:MOS,N-CH;60V,0.115A,7.5 OHM
A1Q3	151-5000-00			TRANSISTOR,SIG:BIPOLAR,PNP;40V,200MA,250MHZ,AMPL
A1Q4	151-5021-00			TRANSISTOR,SIG:BIPOLAR,NPN;40V,600MA,300MHZ,AMPL

Replaceable Electrical Parts

Component Number	Tektronix Part Number	Serial / Assembly Number		Name & Description
		Effective	Discontinued	
A1Q5	151-5021-00			TRANSISTOR,SIG:BIPOLAR,NPN;40V,600MA,300MHZ,AMPL
A1Q6	151-5000-00			TRANSISTOR,SIG:BIPOLAR,PNP;40V,200MA,250MHZ,AMPL
A1Q7	151-5066-00			TRANSISTOR,SIG:MOS,N-CH;60V,0.115A,7.5 OHM
A1Q8	151-5088-00			TRANSISTOR,PWR:MOS,P-CH;30V,4.6A,0.07/0.135
A1Q9	151-5088-00			TRANSISTOR,PWR:MOS,P-CH;30V,4.6A,0.07/0.135
A1Q10	151-5001-00			TRANSISTOR,SIG:BIPOLAR,NPN;40V,200MA,300MHZ,AMPL
A1Q11	151-5066-00			TRANSISTOR,SIG:MOS,N-CH;60V,0.115A,7.5 OHM
A1Q12	151-5044-00			TRANSISTOR,PWR:BIPOLAR,PNP;100V,3.0A,3.0MHZ,AMPL
A1Q13	151-5016-00			TRANSISTOR,SIG:BIPOLAR,PNP;20V,30MA,600MHZ,AMPL
A1R1	321-5048-00			RES,FXD:THICK FILM;332K OHM,1%,0.125W,TC=100 PPM
A1R2	321-5047-00			RES,FXD:THICK FILM;100K OHM,1%,0.125W,TC=100 PPM
A1R3	321-5030-00			RES,FXD:THICK FILM;10.0K OHM,1%,0.125W,TC=100 PPM
A1R4	321-5000-00			RES,FXD:THICK FILM;10 OHM,1%,0.125W,TC=100PPM
A1R5	307-5041-01			RES,NTWK FXD:FILM;(15),4.7K OHM,2%,0.08W EACH,50PPM
A1R6	321-5001-00			RES,FXD:THICK FILM;12.1 OHM,1%,0.125W,TC=100 PPM
A1R7	321-5420-00	671-2967-11		RES,FXD,FILM; 475 OHM,1%,50V,63MW;0603
A1R8	321-5008-00		671-2967-10	RES,FXD:THICK FILM;150 OHM,1%,0.125W,TC=100
	321-5460-00	671-2967-11		RES,FXD,FILM; 1.82K OHM,1%,50V,62.5MW;0603,SMD
A1R9	321-5422-00	671-2967-11		RES,FXD,FILM; 2.00K OHM,1%,50V,62.5MW;0603,SMD
A1R10	321-5446-00	671-2967-11		RES,FXD,FILM; 56.2 OHM,1%,50V,62.5MW;0603
A1R11	321-5010-00		671-2967-10	RES,FXD:THICK FILM;221 OHM,1%,0.125W,TC=100
	321-5448-00	671-2967-11		RES,FXD,FILM; 75.0 OHM,1%,50V,62.5MW;0603
A1R12	321-5010-00		671-2967-10	RES,FXD:THICK FILM;221 OHM,1%,0.125W,TC=100
	321-5448-00	671-2967-11		RES,FXD,FILM; 75.0 OHM,1%,50V,62.5MW;0603
A1R13	321-5008-00			RES,FXD:THICK FILM;150 OHM,1%,0.125W,TC=100
A1R14	321-5113-00			RES,FXD:THICK FILM;75 OHM,1%,0.125W,TC=100PPM
A1R15	321-5451-00	671-2967-11		RES,FXD,FILM; 150 OHM,1%,50V,62.5MW;0603,SMD
A1R17	321-5008-00			RES,FXD:THICK FILM;150 OHM,1%,0.125W,TC=100
A1R19	321-5029-00			RES,FXD:THICK FILM;8.25K OHM,1%,0.125W,TC=100 PPM
A1R20	321-5029-00			RES,FXD:THICK FILM;8.25K OHM,1%,0.125W,TC=100 PPM
A1R22	321-5045-00			RES,FXD:THICK FILM;68.1 OHM,1%,0.125W,TC=100 PPM
A1R25	321-5045-00			RES,FXD:THICK FILM;68.1 OHM,1%,0.125W,TC=100 PPM
A1R30	321-5087-00			RES,FXD,FILM;620 OHM,5%,0.125W
A1R31	311-5034-00			RES,VAR,TRMR:CERMET;2K OHM,25%,0.25W,4MM SQ,TOP ADJ
A1R32	321-5266-00			RES,FXD:THICK FILM;11K OHM,1%,0.125W,TC=100
A1R33	321-5281-00			RES,FXD:THICK FILM;2K OHM,1%,0.125W,TC=100PPM
A1R34	321-5051-00			RES,FXD:THICK FILM;0 OHM,1%,0.125W,TC=100 PPM
A1R35	321-5038-00			RES,FXD:THICK FILM;47.5K OHM,1%,0.125W,TC=100 PPM
A1R36	321-5032-00			RES,FXD:THICK FILM;15.0K OHM,1%,0.125W,TC=100 PPM
A1R37	321-5030-00			RES,FXD:THICK FILM;10.0K OHM,1%,0.125W,TC=100 PPM
A1R38	321-5209-00			RES,FXD,FILM;243 OHM,1%,0.125WTAPE & REEL,SMD
A1R39	321-5049-00			RES,FXD:THICK FILM;1M OHM,1%,0.125W,TC=100PPM
A1R40	311-5040-00			RES,VAR,TRMR:CERMET;10K OHM,25%,0.25W,4MM SQ,TOP ADJ
A1R42	321-5038-00			RES,FXD:THICK FILM;47.5K OHM,1%,0.125W,TC=100 PPM
A1R43	321-5041-00			RES,FXD:THICK FILM;82.5K OHM,1%,0.125W,TC=100 PPM
A1R45	321-5028-00		671-2967-04	RES,FXD:THICK FILM;6.81K OHM,1%,0.125W,TC=100 PPM
	321-5016-00	671-2967-05	671-2967-09	RES,FXD,FILM; THICK FILM;681 OHM,1%,0.125W,TC=100 PPM
	321-5032-00	671-2967-10		RES,FXD,FILM; THICK FILM;15.0K OHM,1%,0.125W,TC=100 PPM
A1R46	321-5016-00		671-2967-04	RES,FXD:THICK FILM;681 OHM,1%,0.125W,TC=100
	321-5051-00	671-2967-05		RES,FXD,FILM; THICK FILM;0 OHM,JUMPER,1%,0.125W,TC=100 PPM
	321-5006-00	671-2967-	671-2967-09	RES,FXD,FILM; THICK FILM;0 OHM,JUMPER,1%,0.125W,TC=100 PPM
	321-5051-00	671-2967-10		RES,FXD,FILM; THICK FILM;0 OHM,JUMPER,1%,0.125W,TC=100 PPM
A1R49	321-5027-00			RES,FXD:THICK FILM;5.62K OHM,1%,0.125W,TC=100 PPM
A1R50	321-5025-00			RES,FXD:THICK FILM;3.92K OHM,1%,0.125W,TC=100 PPM
A1R51	321-5090-00			RES,FXD:THICK FILM; 20K OHM,0.125W,100 PPM,1206,T&R
A1R52	321-5030-00			RES,FXD:THICK FILM;10.0K OHM,1%,0.125W,TC=100 PPM
A1R53	321-5030-00			RES,FXD:THICK FILM;10.0K OHM,1%,0.125W,TC=100 PPM
A1R54	321-5018-00			RES,FXD:THICK FILM;1.0K OHM,1%,0.125W,TC=100 PPM

Replaceable Electrical Parts

Component Number	Tektronix Part Number	Serial / Assembly Number		Name & Description
		Effective	Discontinued	
A1R56	321-5030-00			RES,FXD:THICK FILM;10.0K OHM,1%,0.125W,TC=100 PPM
A1R57	321-5030-00			RES,FXD:THICK FILM;10.0K OHM,1%,0.125W,TC=100 PPM
A1R58	321-5015-00			RES,FXD:THICK FILM;562 OHM,1%,0.125W,TC=100
A1R59	321-5000-00			RES,FXD:THICK FILM;10 OHM,1%,0.125W,TC=100PPM
A1R60	321-5007-00		671-2967-02	RES,FXD:THICK FILM;121 OHM,1%,0.125W,TC=100
	321-5014-00	671-2967-03	671-2967-10	RES,FXD:THICK FILM;475 OHM,1%,0.125W,TC=100
A1R61	321-5006-00			RES,FXD:THICK FILM;100 OHM,1%,0.125W,TC=100
A1R62	321-5006-00			RES,FXD:THICK FILM;100 OHM,1%,0.125W,TC=100
A1R63	321-5006-00			RES,FXD:THICK FILM;100 OHM,1%,0.125W,TC=100
A1R64	321-5006-00			RES,FXD:THICK FILM;100 OHM,1%,0.125W,TC=100
A1R65	321-5006-00			RES,FXD:THICK FILM;100 OHM,1%,0.125W,TC=100
A1R66	321-5006-00			RES,FXD:THICK FILM;100 OHM,1%,0.125W,TC=100
A1R67	321-5006-00			RES,FXD:THICK FILM;100 OHM,1%,0.125W,TC=100
A1R68	321-5006-00			RES,FXD:THICK FILM;100 OHM,1%,0.125W,TC=100
A1R69	321-5006-00			RES,FXD:THICK FILM;100 OHM,1%,0.125W,TC=100
A1R70	321-5006-00			RES,FXD:THICK FILM;100 OHM,1%,0.125W,TC=100
A1R71	321-5018-00			RES,FXD:THICK FILM;1.0K OHM,1%,0.125W,TC=100 PPM
A1R72	321-5030-00			RES,FXD:THICK FILM;10.0K OHM,1%,0.125W,TC=100 PPM
A1R73	321-5030-00			RES,FXD:THICK FILM;10.0K OHM,1%,0.125W,TC=100 PPM
A1R74	321-5047-00			RES,FXD:THICK FILM;100K OHM,1%,0.125W,TC=100 PPM
A1R75	321-5166-00			RES,FXD:THICK FILM;150K OHM,1%,0.125W,TC=100 PPM
A1R76	321-5048-00			RES,FXD:THICK FILM;332K OHM,1%,0.125W,TC=100 PPM
A1R77	321-5049-00			RES,FXD:THICK FILM;1M OHM,1%,0.125W,TC=100PPM
A1R78	321-5010-00			RES,FXD:THICK FILM;221 OHM,1%,0.125W,TC=100
A1R79	321-5045-00			RES,FXD:THICK FILM;68.1 OHM,1%,0.125W,TC=100 PPM
A1R80	321-5022-00			RES,FXD:THICK FILM;2.21K OHM,1%,0.125W,TC=100 PPM
A1R81	321-5024-00			RES,FXD:THICK FILM;3.32K OHM,1%,0.125W,TC=100 PPM
A1R82	321-5000-00			RES,FXD:THICK FILM;10 OHM,1%,0.125W,TC=100PPM
A1R83	321-5009-00			RES,FXD:THICK FILM;182 OHM,1%,0.125W,TC=100
A1R84	321-5045-00			RES,FXD:THICK FILM;68.1 OHM,1%,0.125W,TC=100 PPM
A1R85	317-0101-00	671-2967-02	671-2967-05	RES,FXD:CMPSN;100 OHM,5%,0.125W
	321-5006-00	671-2967-06	671-2967-10	RES,FXD,FILM; 100 OHM,1%,0.125W,TC=100 PPM;1206
	321-5417-00	671-2967-11		RES,FXD,FILM; 100 OHM,1%,50V,62MW;0603,SMD
A1R86	321-5018-00	671-2967-06		RES,FXD,FILM; 1.0K OHM,1%,0.125W,TC=100 PPM;1206
A1R87	321-5030-00	671-2967-05		RES,FXD,FILM; 10.0K OHM,1%,0.125W,TC=100 PPM;1206
A1R90	315-0471-00	671-2967-05	671-2967-05	RES,FXD,FILM; 470 OHM,5%,0.25W,MI
	315-5014-00	671-2967-06	671-2967-09	RES,FXD,FILM; THICK FILM;475 OHM,1%,0.125W,TC=100 PPM;1206,T&R
A1RT1	307-0126-00	671-2967-01		RES,THERMAL; 100 OHM,10%,NTC
A1TP3	214-4085-00		671-2967-01	TERM,TEST POINT:0.070 ID,0.220 H,0.063 DIAPCB,0.015 X 0.032 BRASS,W/RED NYLON COLLAR
	214-4705-00	671-2967-02		TEST POINT; SMD,TEST POINT;FEMALE,STR,0.09 H X 0.112 X 0.150 ID,TIN 0.112 X 0.15 PCB
A1TP4	214-4085-00		671-2967-01	TERM,TEST POINT:0.070 ID,0.220 H,0.063 DIAPCB,0.015 X 0.032 BRASS,W/RED NYLON COLLAR
	214-4705-00	671-2967-02		TEST POINT; SMD,TEST POINT;FEMALE,STR,0.09 H X 0.112 X 0.150 ID,TIN 0.112 X 0.15 PCB
A1U1	156-5074-02			IC,DIGITAL:CMOS,FLIP FLOP;DUAL D-TYPE
A1U2	156-6871-00		671-2967-01	IC,DIGITAL:CMOS,PLD;FPGA,XC4000 FAMILY,4013,576 CLBS,192 IOBS,160 I/O,5 NS
	156-7023-00	671-2967-02	671-2967-06	IC,DIGITAL:CMOS,PLD;FPGA,XC4000 FAMILY,4013,576 CLBS,192 IOBS,160 I/O,4 NS
	156-7023-01	671-2967-07		IC,DIGITAL:CMOS,PLD;FPGA,XC4000E FAMILY,4013E,576 CLBS,192 IOBS,160 I/O
A1U3	156-6714-00			IC,LINEAR:BIPOLAR,SW-REGULATOR;STEP-DOWN/BUCK,5.0V,500MA,4%,SHUTDOWN
A1U4	156-6663-00		671-2967-00	IC,MEMORY:CMOS,EPRM;128K X 8,120NS,5V PRGM
	163-0257-00	671-2967-01	671-2967-03	IC,MEMORY:CMOS,EPRM;128K X 8,120NS,5V PRGM
	163-0257-02	671-2967-04		IC,MEMORY; CMOS,EPRM;128K X 8,120NS,5V,PRGM
				ATTACHING PART
	136-5011-00	671-2967-02	671-2967-10	SOCKET,PLCC; SMD,32 POS,0.05 CTR,0.800 X 0.700W,0.200 H,BE/CU,TIN,W/O PLZ POSTS
	136-5011-01	671-2967-11		SOCKET,PLCC; SMD,32 POS,0.05 CTR,0.800 X 0.700W,0.200 H,BE/CU,TIN,W/O PLZ POSTS
				END ATTACHING PART
A1U5	156-6661-00			IC,PROCESSOR:CMOS,MICRO COMPUTER;8-BIT,1K RAM,A/D,D/A,12MHZ
A1U6	156-6663-00		671-2967-01	IC,MEMORY:CMOS,EPRM;128K X 8,120NS,5V PRGM

Replaceable Electrical Parts

Component Number	Tektronix Part Number	Serial / Assembly Number		Name & Description
		Effective	Discontinued	
	163-0258-00	671-2967-02	671-2967-03	IC, MEMORY: CMOS, EPROM; 128K X 8, 120NS, 5V PRGM
	163-0258-01	671-2967-04		IC, MEMORY; CMOS, EPROM; 125K X 8, 120NS, 5V, PRGM **ATTACHING PART**
	136-5011-00	671-2967-02	671-2967-10	SOCKET, PLCC; SMD, 32 POS, 0.05 CTR, 0.800 X 0.700W, 0.200 H, BE/CU, TIN, W/O PLZ POSTS
	136-5011-01	671-2967-11		SOCKET, PLCC; SMD, 32 POS, 0.05 CTR, 0.800 X 0.700W, 0.200 H, BE/CU, TIN, W/O PLZ POSTS **END ATTACHING PART**
A1U7	156-6664-00			IC, MISC: CMOS, INTERFACE; DUAL RS-232 DRIVER/RECEIVER, +5V VCC, NEG INPUT THRESHOLD ON ONE RECEIVER
A1U8	156-6665-00			IC, MISC: CMOS, PWR SUPPLY SUPERVISOR; MPU RESET GEN, 5V SUPPLY SENSING, MPU WATCHDOG TIMER
A1U9	156-6491-00			IC, MEMORY: CMOS, ROM ; 12 LINES X 24 COLUMN TV
A1U10	156-5588-01			IC, LINEAR: BIPOLAR, V REF; POS, 2.5V, 1.0%, 40PPM, SERIES
A1U11	155-0416-00		671-2967-10	IC, ASIC: BIPOLAR, VIDEO SERIALIZER; FULL CUSTOM, M763
	155-8711-00	671-2967-11		IC, DIGITAL; BIPOLAR, HDTV; DIGITAL VIDEO SERIALIZER; GS9032, TQFP44, DS1
A1U13	156-6666-00			IC, LINEAR: BIPOLAR, AMPL; FM IF/DETECTOR, FSK DATA SHAPER, W/RSSI
A1U16	156-6668-00			IC, MISC: ECL, MISC; GENLINUX CA DRVR W/TWO ADJUST OUTPUTS
A1U18	156-6660-00			IC, ASIC: BIPOLAR, CUSTOM; DESERIALIZER, SC2307-00, PLCC44
A1U20	156-6669-00			IC, ASIC: GATE ARRAY; ENOLA VIDEO CO-PROCESSOR
A1U21	156-6794-00		671-2967-08	IC, MEMORY: CMOS, SRAM; 32K X 8, 15NS, 5C2568, SOJ28.300
	156-9376-00	671-2967-09		IC, MEMORY: CMOS, SRAM; 32K X 8, 15NS, 5C2568, SOJ28.300
A1U22	156-5081-01		671-2967-00	IC, DIGITAL: HCTCMOS, GATE; HEX INVERTER
	156-5155-01	671-2967-01		IC, DIGITAL: HCMOS, GATE; HEX INVERTER; 74HC04
A1U23	156-6867-00			IC, MEMORY: CMOS, ROM ; 12 LINES X 24 COLUMN TV
A1U25	156-5441-01			IC, LINEAR: BIPOLAR, VOLTAGE REGULATOR; POSITIVE, ADJUSTABLE, 100MA, 2% MICROPOWER
A1U26	156-6794-00		671-2967-08	IC, MEMORY: CMOS, SRAM; 32K X 8, 15NS, 5C2568, SOJ28.300
	156-9376-00	671-2967-09		IC, MEMORY: CMOS, SRAM; 32K X 8, 15NS, 5C2568, SOJ28.300
A1VR1	152-5046-00			DIODE, ZENER;; 20V, 5%, 225MW
A1VR2	152-5046-00			DIODE, ZENER;; 20V, 5%, 225MW
A1Y1	158-0449-00			OSCILLATOR: TCXO; 27MHZ, 1PPM, 5PPM MIN ADJUSTIBILITY, 3 PIN PACKAGE, DIP14 COMPATIBLE
A1Y2	158-5028-00			XTAL UNIT, QTZ: 12.0 MHZ, +/- 0.01%, PRL, CLH, TYPE FPX-SM
A2	671-2586-01			CIRCUIT BD ASSY: KEYBOARD
A2J1	131-5781-00			CONN, HDR: PCB; MALE, STR, 2 X 10, 0.1 CTR, 0.380
A3	119-4506-00		B040554	DISPLAY, MODULE.; LCD; 16 CHARACTERS X 2 LINES, 5 X 7 DOT MATRIX, TRANSFLECTIVE, YEL/GRN LED
	119-5566-00	B040555	B041212	DISPLAY MODULE; LCD; 16 CHARACTERS X 2 LINES, 5 X 7 DOT MATRIX, TRANSFLECTIVE, YEL/GRN LED BACKLIGHT, WIDE TEMP RANGE
	119-5566-01	B041213	B052014	DISPLAY MODULE; LCD; 16 CHARACTERS X 2 LINES, 5 X 7 DOT MATRIX, TRANSFLECTIVE, YEL/GRN LED BACKLIGHT, WIDE TEMP RANGE
	119-5566-02	B052015		DISPLAY MODULE; LCD; 16 CHARACTERS X 2 LINES, 5 X 7 DOT MATRIX, TRANSFLECTIVE, YEL/GRN LED BACKLIGHT, WIDE TEMP RANGE
A4	671-3227-00			CKT BD ASSY: REAR PANEL BOARD
A4J1	131-0391-00			CONN, RF JACK: SMB; 50 OHM, STR, PCB, GOLD/GOLD, 0.293 H X 0.155 TAIL, 3/0.045 SQ TAIL 0.038 DIA CTRCOND, 0.2 SQ PCB, 0.312 HEX
A4J2	131-5436-00			CONN, RF JACK: BNC; 50 OHM, FEMALE, STR, PCB, 0.450 H X (4)0.040 SQ, 0.189 TAIL, ON 0.250 CTRPCB
A4J3	131-5436-00			CONN, RF JACK: BNC; 50 OHM, FEMALE, STR, PCB, 0.450 H X (4)0.040 SQ, 0.189 TAIL, ON 0.250 CTRPCB
A4J4	131-5436-00			CONN, RF JACK: BNC; 50 OHM, FEMALE, STR, PCB, 0.450 H X (4)0.040 SQ, 0.189 TAIL, ON 0.250 CTRPCB
W8	174-3183-00			CABLE ASSEMBLY: (CONNECTED @ A1J8 & A4J1)



Diagrams and Circuit Board Illustrations

Diagrams and Circuit Board Illustrations

Symbols

Graphic symbols and class designation letters are based on ANSI Standard Y32.2-1975.

Logic symbology is based on ANSI Y32.14-1973 in terms of positive logic. Logic symbols depict the logic function performed and may differ from the manufacturer's data.

Overline, parenthesis, or leading slash indicate a low asserting state.

Example: $\overline{\text{ID CONTROL}}$, (ID CONTROL), or /ID CONTROL.

Abbreviations are based on ANSI Y1.1-1972.

Other ANSI standards that are used in the preparation of diagrams by Tektronix, Inc. are:

- Y14.15, 1966 — Drafting Practices.
- Y14.2, 1973 — Line Conventions and Lettering.
- Y10.5, 1968 — Letter Symbols for Quantities Used in Electrical Science and Electrical Engineering.

Component Values

Electrical components shown on the diagrams are in the following units unless noted otherwise:

Capacitors: Values one or greater are in picofarads (pF).
Values less than one are in microfarads (μF).

Resistors: Values are in Ohms (Ω).

Graphic Items and Special Symbols Used in This Manual

Each assembly in the instrument is assigned an assembly number (for example A23). The assembly number appears in the title on the diagram, in the lookup table for the schematic diagram, and corresponding component locator illustration. The Replaceable Electrical Parts list is arranged by assembly in numerical sequence; the components are listed by component number.

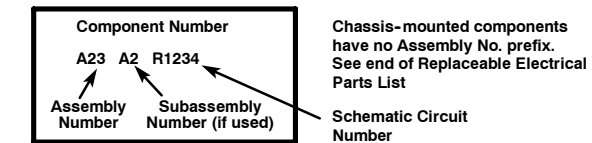

Grid Coordinates

The schematic diagram and circuit board component location illustration have grids. A lookup table with the grid coordinates is provided for ease of locating the component. Only the components illustrated on the facing diagram are listed in the lookup table.

When more than one schematic diagram is used to illustrate the circuitry on a circuit board, the circuit board illustration will only appear opposite the first diagram; the lookup table will list the diagram number of other diagrams that the other circuitry appears on.

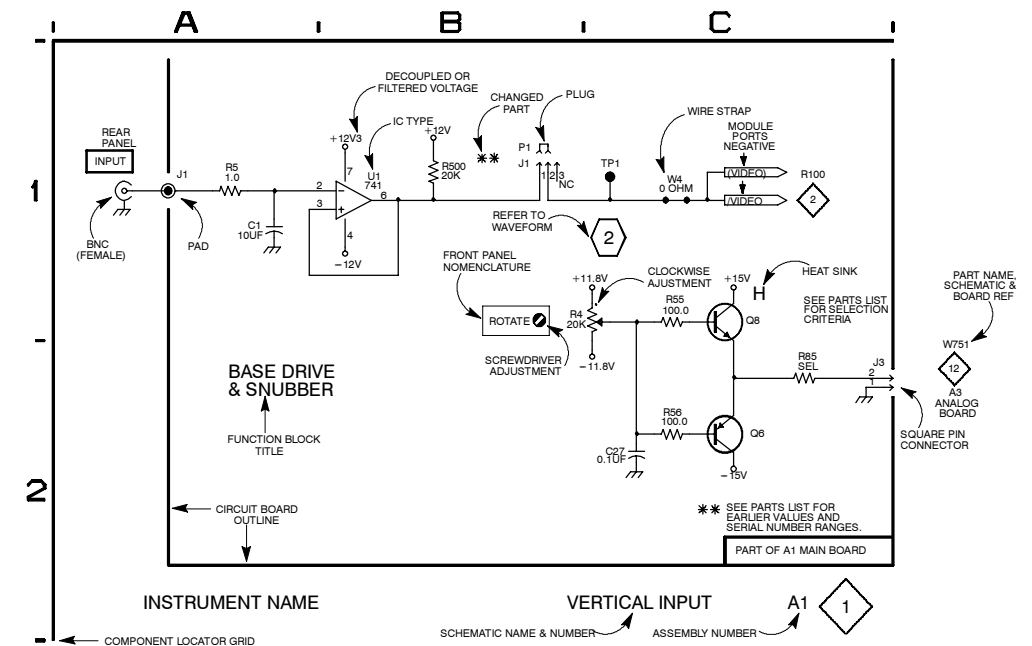

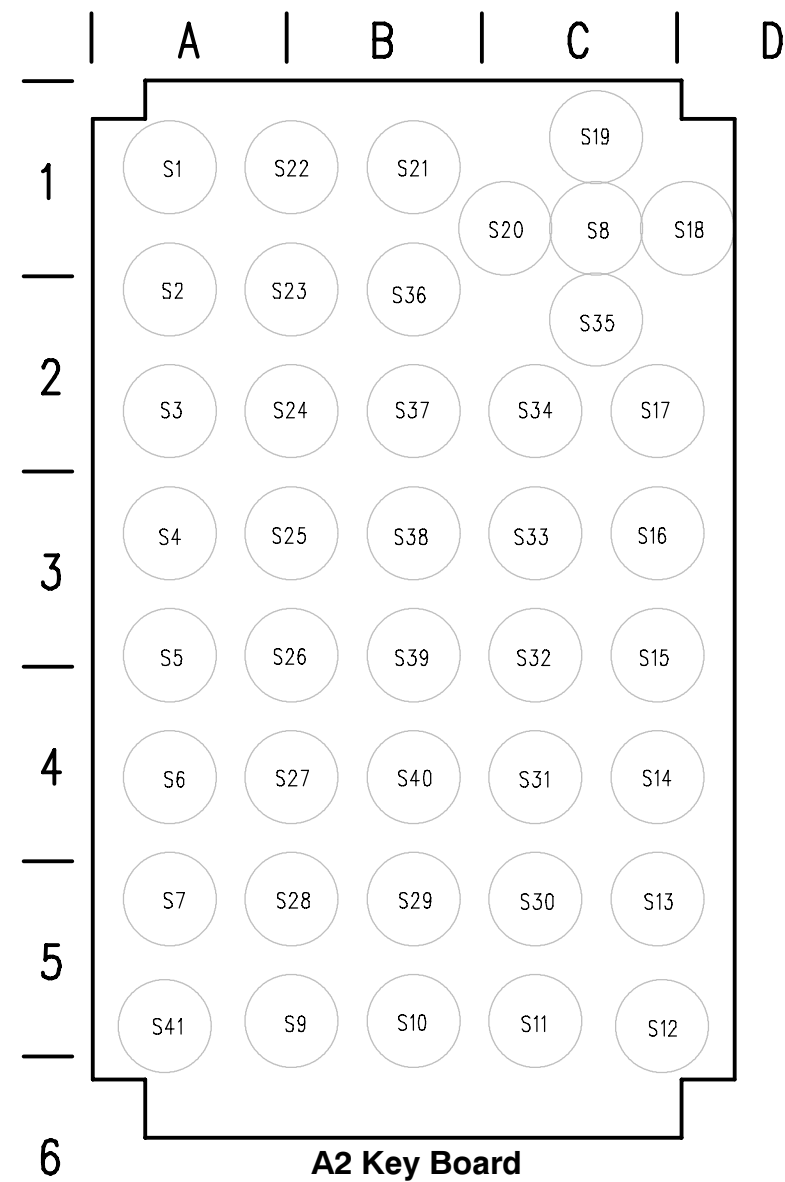

 **Static Sensitive Devices**
See Maintenance Section

**A2 Schematic Diagram <1>
Component Locator Chart**

Comp No	Diag Loc	Bd Loc	Comp No	Diag Loc	Bd Loc	Comp No	Diag Loc	Bd Loc
J1	H1	B6	S14	D3	C4	S28	B4	A5
S1	A1	A1	S15	D3	C3	S29	C4	B5
S2	A1	A1	S16	D2	C3	S30	D4	C5
S3	A2	A2	S17	D2	C2	S31	D3	C4
S4	A2	A3	S18	D1	C1	S32	D3	C3
S5	A3	A3	S19	D1	C1	S33	D2	C3
S6	A3	A4	S20	D1	B1	S34	D2	C2
S7	A4	A5	S21	C1	B1	S35	D1	C2
S8	A4	C1	S22	B1	A1	S36	C1	B1
S9	B4	A5	S23	B1	A1	S37	C2	B2
S10	C4	B5	S24	B2	A2	S38	C2	B3
S11	D4	C5	S25	B2	A3	S39	C3	B3
S12	D4	C5	S26	B3	A3	S40	C3	B4
S13	D4	C5	S27	B3	A4	S41	G2	A5

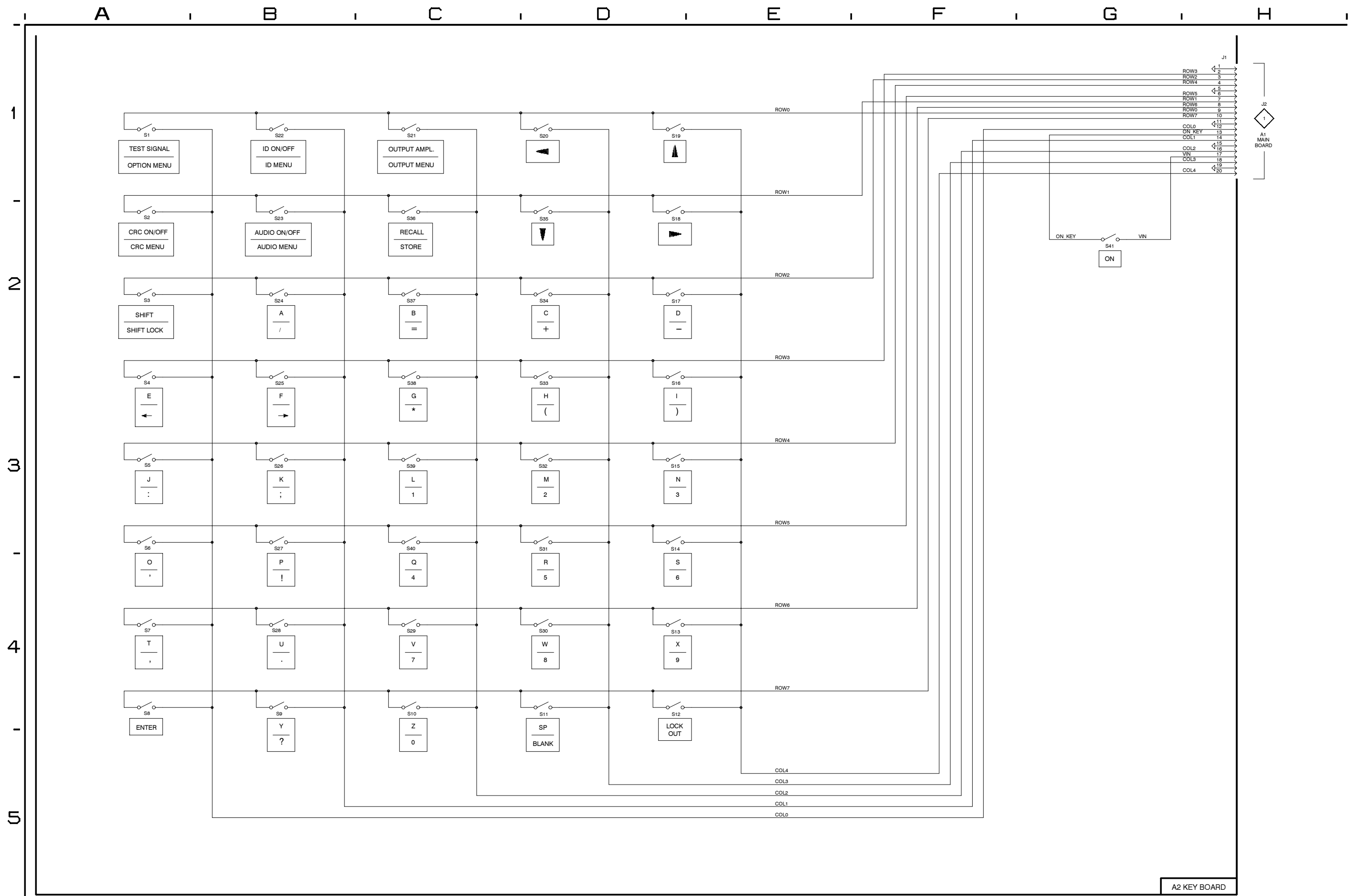

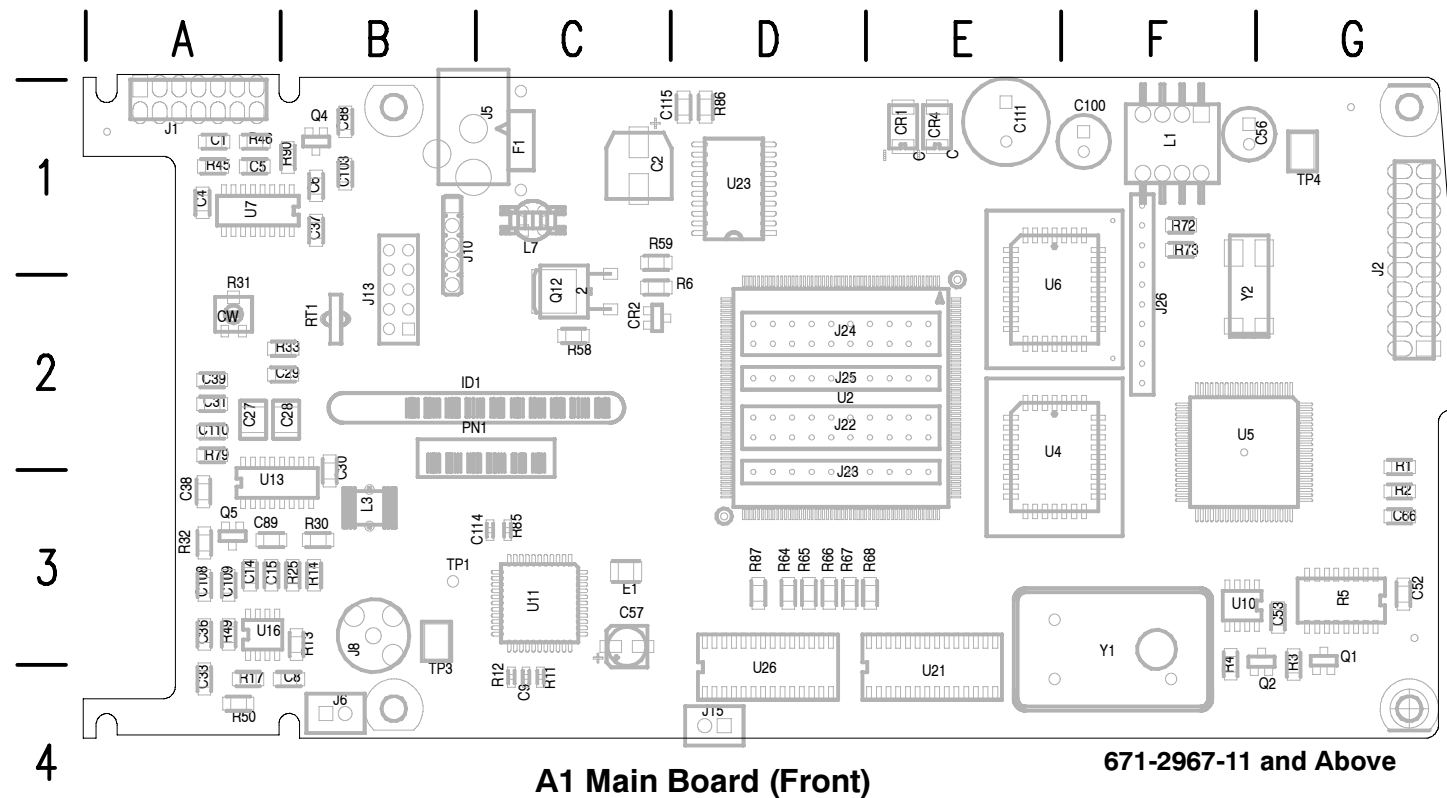

A1 Main Board (Front)

671-2967-11 and Above

Static Sensitive Devices
See Maintenance Section

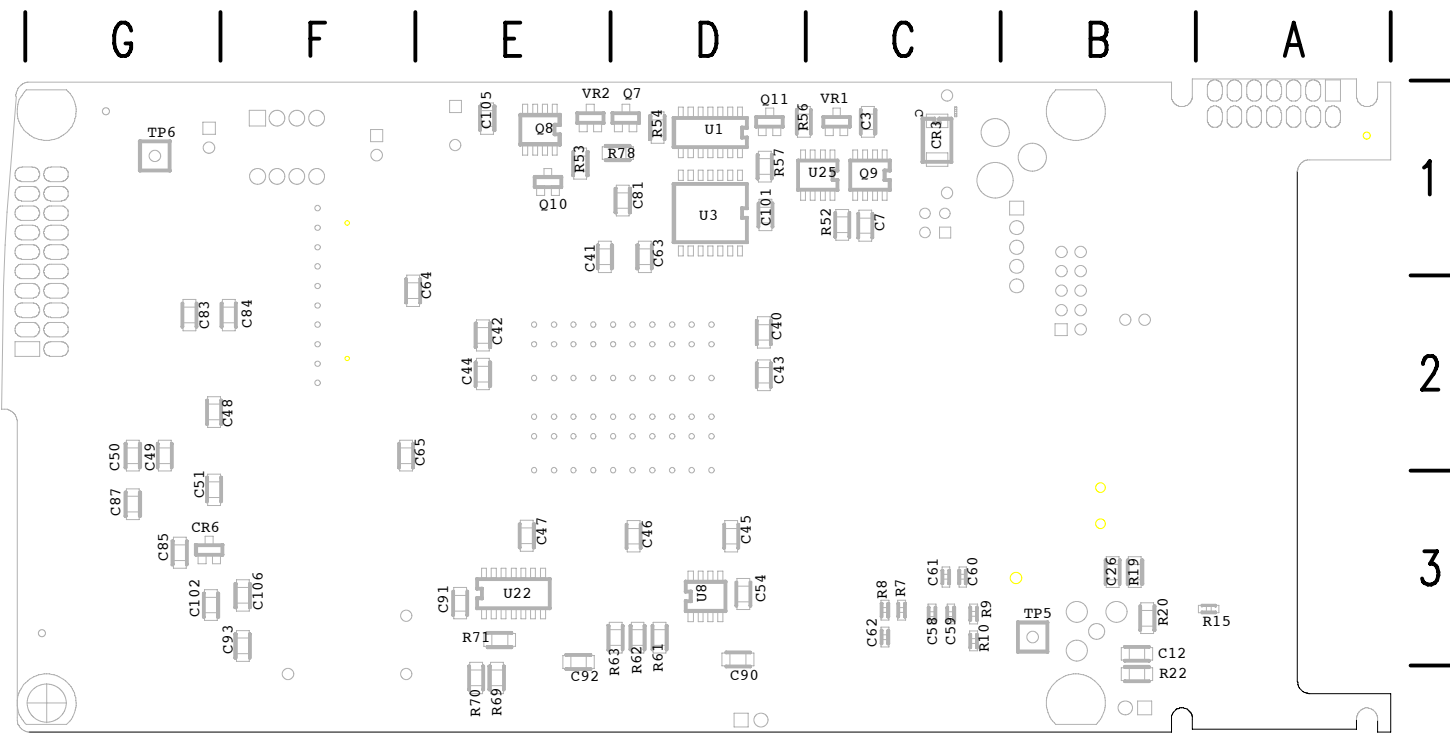

A1 Main Board (Back)

671-2967-11 and Above

A1 Main Board and Schematic Diagram <1> Component Locator Chart
(671-2967-11 and Above)

(With cross-references to schematic diagrams 1, 2, and 3.)

A1 Main Board. Partial assembly A1 also shown on schematics 2 and 3

Comp No	Diag No	Diag Loc	Bd Loc	Comp No	Diag No	Diag Loc	Bd Loc	Comp No	Diag No	Diag Loc	Bd Loc	Comp No	Diag No	Diag Loc	Bd Loc
C1	1	F1	A1	C82	3	G3	C2					R64	1	C8	D3
C2	3	A3	C1	C83 †	1	C2	G2	Q1	1	B2	G3	R65	1	C8	D3
C3 †	3	A4	C1	C84 †	1	D2	F2	Q2	1	E1	G4	R66	1	C8	D3
C4	1	E8	A1	C85 †	1	C1	G3	Q4	1	F1	B1	R67	1	C8	D3
C5	1	E7	A1	C87 †	1	C2	G3	Q5	2	D4	A3	R68	1	C8	E3
C6	1	E7	B1					Q7 †	3	C4	D1	R69 †	1	D8	E4
C7 †	3	A2	C1	C88	1	F1	B1					R70 †	1	D8	E4
				C89	2	D4	A3	Q8 †	3	C5	E1				
C8	2	C4	B4	C90 †	3	D6	D4	Q9 †	3	A3	C1	R71 †	1	E7	E3
C9	2	C3	C4	C91 †	3	D6	E3	Q10 †	3	C4	E1	R72	1	C8	F1
C12 †	2	C5	B3	C92 †	3	D7	E4	Q11 †	3	B6	D1	R73	1	C8	F1
C14	2	C4	A3	C93 †	3	D7	F3	Q12	3	B2	C2	R78 †	3	C4	D1
C15	2	C5	A3									R79	2	D6	A2
				C100	3	D6	F1	R1	1	B1	G2	R85	2	C1	C3
C26 †	2	D5	B3	C101 †	3	A6	D1	R2	1	C1	G3	R86	3	B7	D1
C27	2	D7	A2	C102 †	1	A5	F3	R3	1	B2	G4	R87	1	B2	D3
C28	2	D5	B2	C103	1	E8	B1	R4	1	E1	F4	R90	1	F1	B1
C29	2	D5	A2	C105 †	3	A3	E1	R5	1	A2	G3				
C30	2	D6	B3	C106 †	1	C1	F3	R6	3	B2	C2	RT1	2	D7	B2
C31	2	D6	A2					R7 †	2	C2	C3				
				C108	2	C4	A3	R8 †	2	C2	C3	TP1	2	B2	B3
C33	2	D4	A4	C109	2	C4	A3	R9 †	2	D2	C3	TP3	3	D5	B3
C36	3	D7	A3	C110	2	D6	A2	R10 †	2	D2	C3	TP4	3	D5	G1
C37	3	C6	B1	C111	3	C6	E1					TP5 †	3	D5	B3
C38	3	D6	A3	C114	2	C2	C3	R11	2	C3	C4	TP6 †	3	D5	G1
C39	3	D6	A2	C115	3	B7	D1	R12	2	C3	C4				
C40 †	3	C7	D2					R13	2	D4	B3	U1A †	3	B7	D1
				CR1	3	C5	E1	R14	2	D5	B3	U1B †	3	A6	D1
C41 †	3	C7	D1	CR2	3	B2	C1	R15 †	2	C3	A3	U2	1	B5	D2
C42 †	3	C7	E2	CR3 †	3	A1	C1	R17	2	C4	A4	U3 †	3	C3	D1
C43 †	3	C7	D2	CR4	3	C4	E1	R19 †	2	C5	B3	U4	1	A3	E2
C44 †	3	C7	E2	CR6 †	1	C2	G3	R20 †	2	C5	B3	U5	1	C2	F2
C45 †	3	C6	D3									U6	1	A7	E2
C46 †	3	C6	D3	E1	3	D6	C3	R22 †	2	C5	B4				
C47 †	3	C7	E3					R25	2	C5	B3	U7	1	E7	A1
				F1	3	A2	C1	R30	2	D5	B3	U8 †	1	B2	D3
C48 †	3	C7	F2					R31	2	D8	A2	U10	1	D1	F3
C49 †	3	C7	G2	J1	1	E2	A1	R32	2	D4	A3	U11	2	C2	C3
C50 †	3	C7	G2	J2	1	A1	G2	R33	2	D7	B2	U13	2	D6	A3
C51 †	3	C7	G3	J5	3	A1	C1	R45	1	F1	A1	U16	2	C3	A3
C52	3	D6	G3	J6	1	E2	B4					U21	1	D7	E4
C53	3	D6	G3	J8	2	C8	B3	R46	1	F1	A1				
C54 †	3	D7	D3	J10	3	B1	B1	R49	2	D4	A3	U22A †	1	E6	E3
				J13	1	F8	B2	R50	2	D4	A4	U22B †	1	B3	E3
C56	3	C6	F1	J15	1	B2	D4	R52 †	3	B3	C1	U22C †	1	D2	E3
C57	3	D6	C3	J22	1	B6	D2	R53 †	3	C4	E1	U23	1	E3	D1
C58 †	3	D7	C3	J23	1	A5	D3	R54 †	3	C4	D1	U25 †	3	A6	C1
C59 †	3	D7	C3	J24	1	A8	D2	R56 †	3	B6	C1	U26	1	C7	D4
C60 †	3	D7	C3	J25	1	D8	D2								
C61 †	3	D7	C3	J26	1	B8	F2	R57 †	3	B6	D1	VR1 †	3	A3	C1
C62 †	3	D7	C3					R58	3	B2	C2	VR2 †	3	C4	E1
				L1A	3	C5	F1	R59	3	B2	D1				
C63 †	3	D7	D1	L1B	3	D6	F1	R61 †	1	C8	D3	Y1	1	E7	F3
C64 †	3	D7	E2	L3	2	D5	B3	R62 †	1	C8	D3	Y2	1	D2	F2
C65 †	3	D7	E2	L7	3	A2	C1	R63 †	1	C8	D3				
C66	1	C1	G3												
C81 †	3	D7	D1												

† = on back of board.

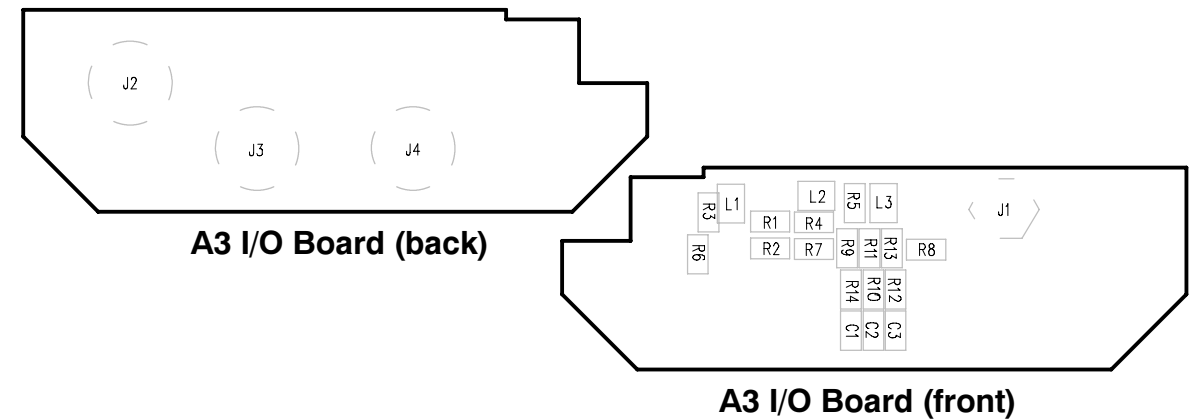

A3 I/O Board (back)

A3 I/O Board (front)

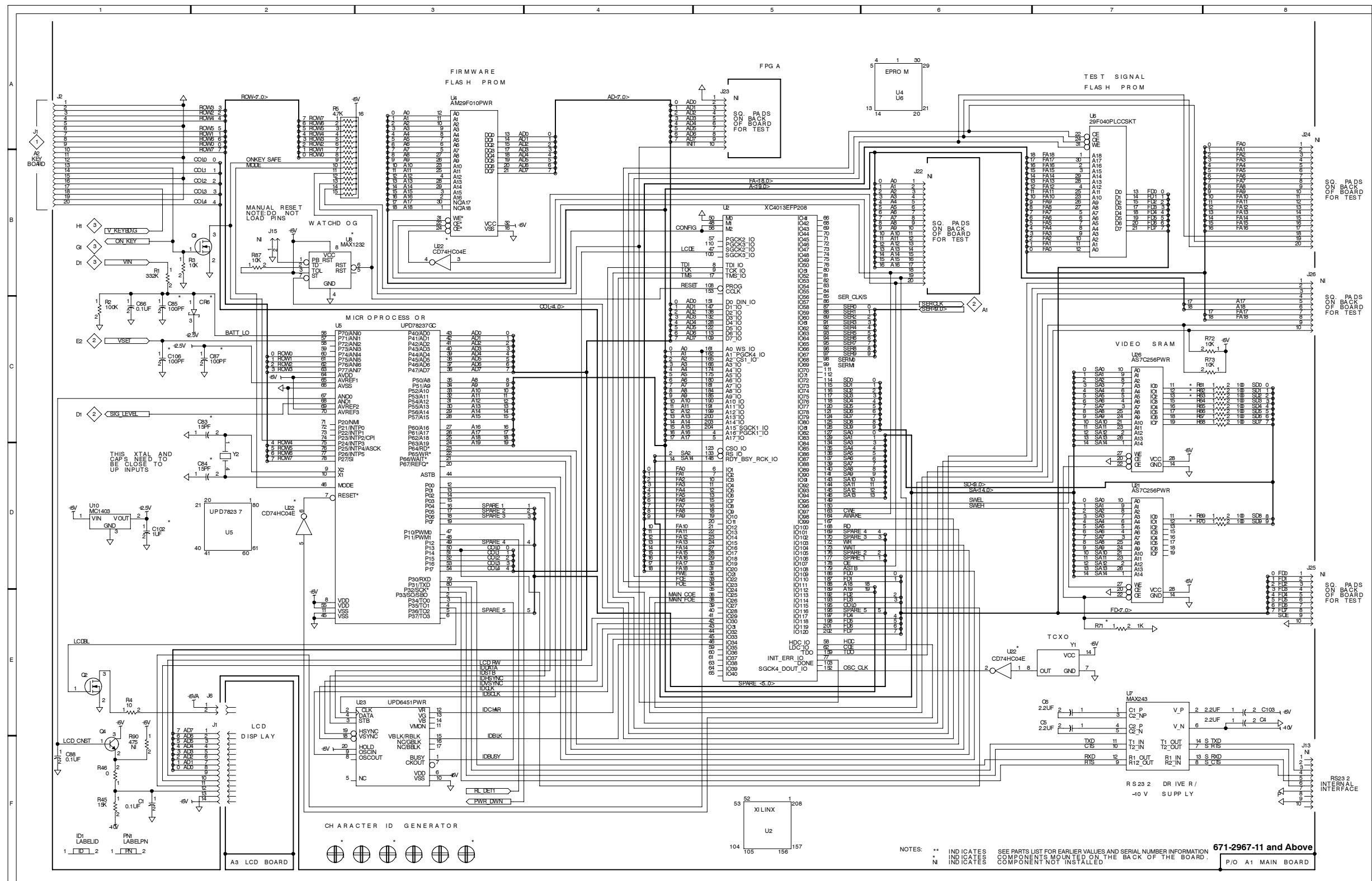

NOTES: ** INDICATES SEE PARTS LIST FOR EARLIER VALUES AND SERIAL NUMBER INFORMATION.
 * INDICATES COMPONENTS MOUNTED ON THE BACK OF THE BOARD.
 N INDICATES COMPONENT NOT INSTALLED.

671-2967-11 and Above
 P/O A1 MAIN BOARD

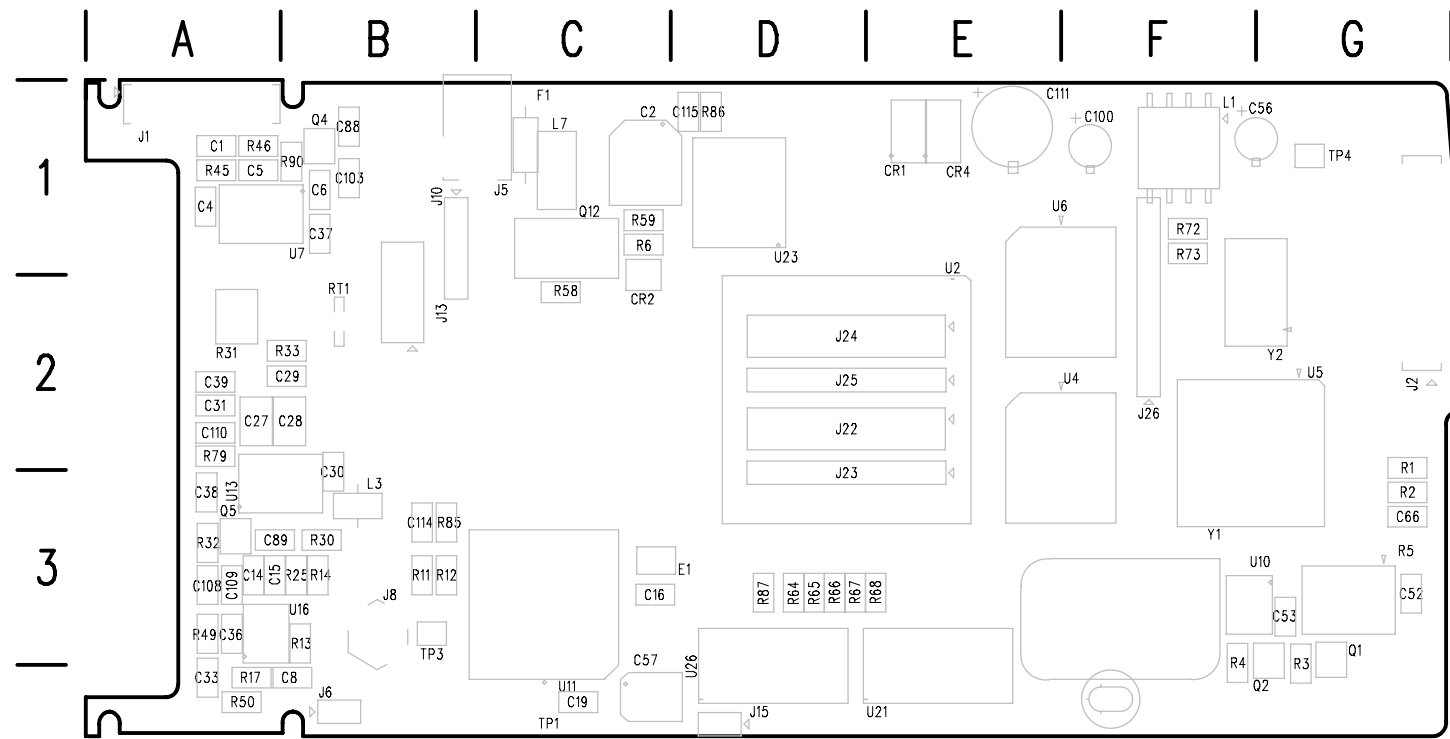

A1 Main Board (Front)

671-2967-02 to 671-2967-10

Static Sensitive Devices
See Maintenance Section

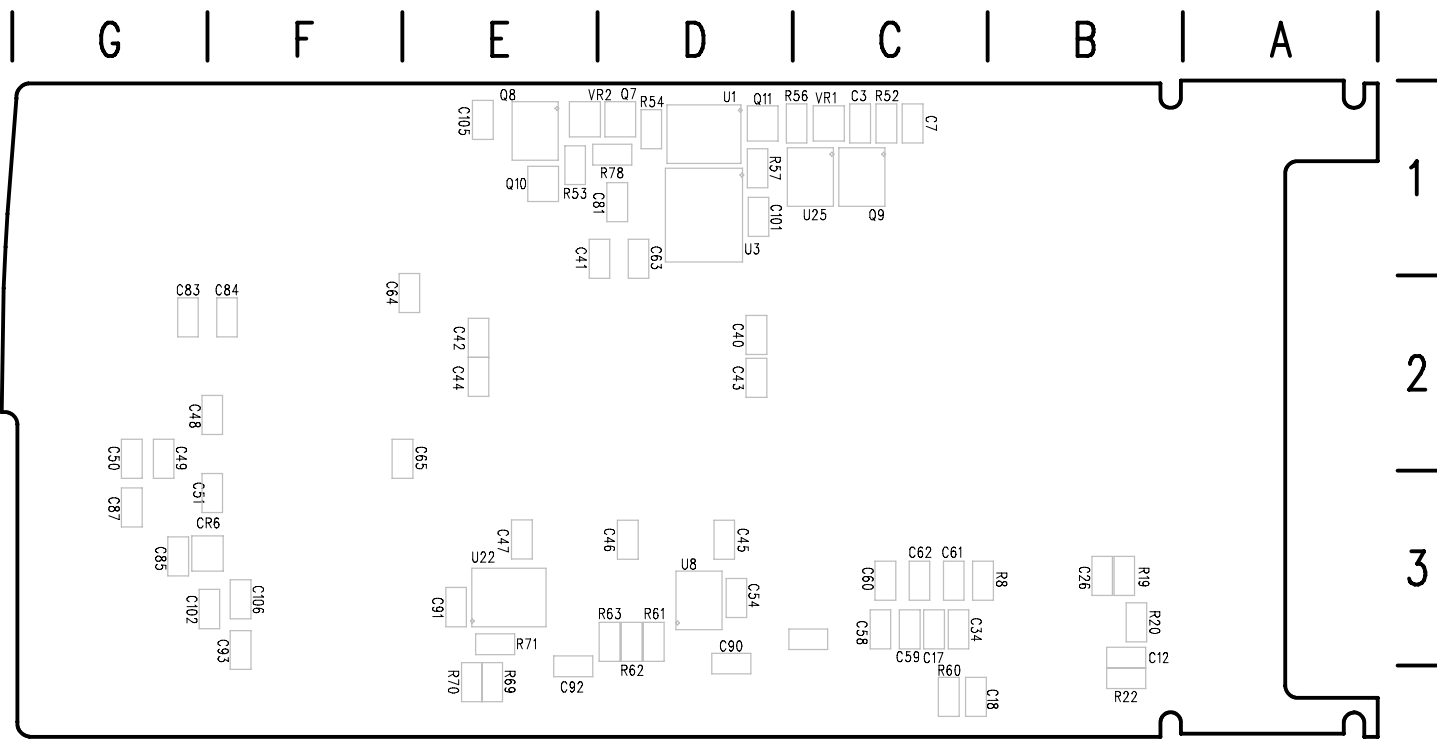

A1 Main Board (Back)

671-2967-02 to 671-2967-10

A1 Main Board and Schematic Diagram <1> Component Locator Chart
(671-2967-02 to 671-2967-10)

(With cross-references to schematic diagrams 1, 2, and 3.)

A1 Main Board. Partial assembly A1 also shown on schematics 2 and 3

Comp No	Diag No	Diag Loc	Bd Loc	Comp No	Diag No	Diag Loc	Bd Loc	Comp No	Diag No	Diag Loc	Bd Loc	Comp No	Diag No	Diag Loc	Bd Loc
C1	1	B5	A1	C66	1	A2	G3	J25	1	H4	D2	R62 †	1	H3	D3
C2	3	D1	C1	C68 †	3	G3	C2	J26	1	H2	F2	R63 †	1	H3	D3
C3 †	3	D1	C1	C69 †	3	G3	C2					R64	1	H3	D3
C4	1	H5	A1	C71 †	3	H3	C2	L1A	3	F2	F1	R65	1	H3	D3
C5	1	G5	A1					L1B	3	F3	F1	R66	1	H3	D3
C6	1	G5	B1	C72 †	3	H3	C2	L3	2	G2	B3	R67	1	H3	D3
C7 †	3	C1	C1	C81 †	3	H3	D1	L7	3	B1	C1	R68	1	H3	D3
				C82	3	G3	C2					R69 †	1	H4	E4
C8	2	E1	B4	C83 †	1	A3	G2	P6	1	B5		R70 †	1	H4	E4
C12 †	2	F1	B3	C84 †	1	A3	F2								
C14	2	E1	A3	C85 †	1	A2	G3	Q1	1	A2	G3				
C15	2	F1	A3	C87 †	1	A3	G3	Q2	1	A5	G4	R71 †	1	G5	E3
C16	2	A1	C3					Q4	1	A5	B1	R72	1	H2	F1
C17 †	2	A2	C3	C88	1	A5	B1	Q5	2	D1	A3	R73	1	G2	F1
C18 †	2	A2	B4	C89	2	D1	A3	Q7 †	3	D2	D1	R78 †	3	D2	D1
				C90 †	3	G3	D4					R79	2	G2	A2
C19	2	B2	C4	C91 †	3	G3	E3	Q8 †	3	E2	E1	R85	2	B1	B3
C26 †	2	F2	B3	C92 †	3	G3	E4	Q9 †	3	C1	C1	R86	3	H2	D1
C27	2	H2	A2	C93 †	3	G3	F3	Q10 †	3	E2	E1				
C28	2	G2	B2	C98	2	B1	C3	Q11 †	3	G1	D1	R87	1	B2	D3
C29	2	F2	A2					Q12	3	B2	C1	R90	1	B5	B1
C30	2	G2	B3	C100	3	F3	F1								
C31	2	G2	A2	C101 †	3	F1	D1	R1	1	A2	G3	RT1	2	H2	B2
				C102 †	1	A5	F3	R2	1	A2	G3				
C33	2	E2	A4	C103	1	H5	B1	R3	1	A2	G4	TP1	2	B2	C4
C34 †	2	B2	C3	C105 †	3	D1	E1	R4	1	A5	F4	TP3	3	F3	B3
C36	3	G2	A3	C106 †	1	A2	F3	R5	1	C1	G3	TP4	3	F3	G1
C37	3	G2	B1	C107 †	2	A1	B3	R6	3	B2	C1				
C38	3	G3	A3					R8 †	2	C1	C3	U1A †	3	G1	D1
C39	3	G3	A2	C108	2	D1	A3					U1B †	3	G1	D1
C40 †	3	G2	D2	C109	2	D1	A3	R11	2	C1	B3	U2	1	E2	D2
				C110	2	G2	A2	R12	2	C1	B3	U3 †	3	C2	D1
C41 †	3	G2	D1	C111	3	F2	E1	R13	2	E1	B3	U4	1	D1	E2
C42 †	3	H2	E2	C114	2	B1	B3	R14	2	F1	B3	U5	1	B2	F2
C43 †	3	H2	D2	C115	3	G2	D1	R17	2	E1	A4	U6	1	G1	E2
C44 †	3	H2	E2					R19 †	2	F1	B3				
C45 †	3	G3	D3	CR1	3	F2	E1	R20 †	2	F1	B3	U7	1	G5	A1
C46 †	3	G3	D3	CR2	3	B2	C1					U8 †	1	B2	D3
C47 †	3	G3	E3	CR3	3	B1	C1	R22 †	2	F1	B4	U10	1	A5	F3
				CR4	3	E2	E1	R25	2	F1	B3	U11	2	B1	C3
C48 †	3	G3	F2	CR6 †	1	A2	F3	R30	2	F2	B3	U13	2	G2	A3
C49 †	3	H3	G2					R31	2	H2	A2	U16	2	C1	A3
C50 †	3	H3	G2	E1	3	G4	C3	R32	2	E2	A3	U21	1	G4	E4
C51 †	3	H3	F3	E2	3	G3	C2	R33	2	H2	A2				
C52	3	G3	G3	F1	3	B1	C1	R45	1	B5	A1	U22A †	1	D2	E3
C53	3	G3	G3	J1	1	B5	A1					U22B †	1	C1	E3
C54 †	3	G3	D3	J2	1	A1	G2	R46	1	B5	A1	U22C †	1	B3	E3
				J5	3	A1	C1	R49	2	E2	A3	U23	1	C5	D1
C56	3	F2	F1	J6	1	B5	B4	R50	2	E2	A4	U25 †	3	F1	C1
C57	3	G4	C4	J8	2	G1	B3	R52 †	3	C1	C1	U26	1	G3	D4
C58 †	3	G4	C3	J10	3	A1	B1	R53 †	3	D2	E1				
C59 †	3	G4	C3	J13	1	H5	B2	R54 †	3	D2	D1	VR1 †	3	C1	C1
C60 †	3	H4	C3					R56 †	3	G1	C1	VR2 †	3	E2	E1
C61 †	3	H4	C3	J15	1	B2	D4								
C62 †	3	H4	C3	J22	1	G1	D2	R57 †	3	F2	D1	Y1	1	C2	F3
				J23	1	E1	D3	R58	3	B2	C2	Y2	1	A3	G2
C63 †	3	G3	D1	J24	1	H1	D2	R59	3	B2	D1				
C64 †	3	H3	E2					R60 †	2	A2	C4				
C65 †	3	H3	E2					R61 †	1	H3	D3				

† = on back of board.

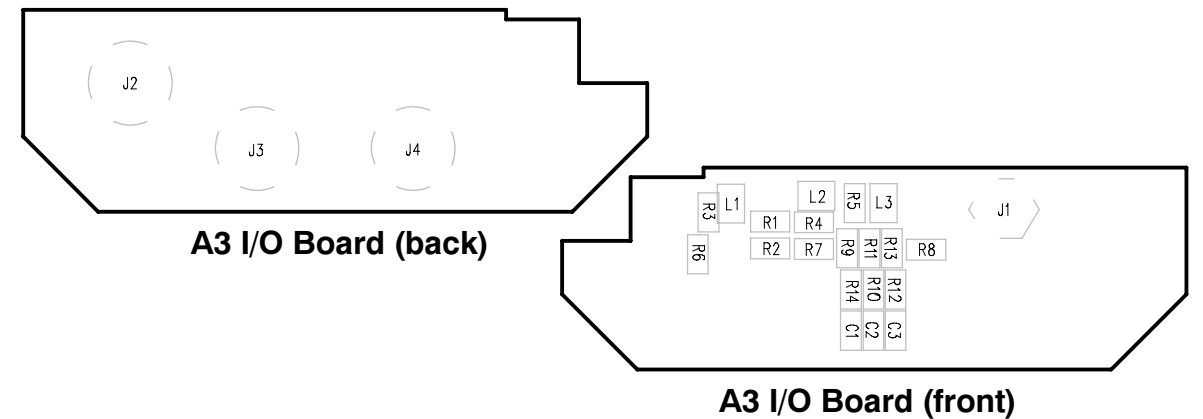

A3 I/O Board (back)

A3 I/O Board (front)

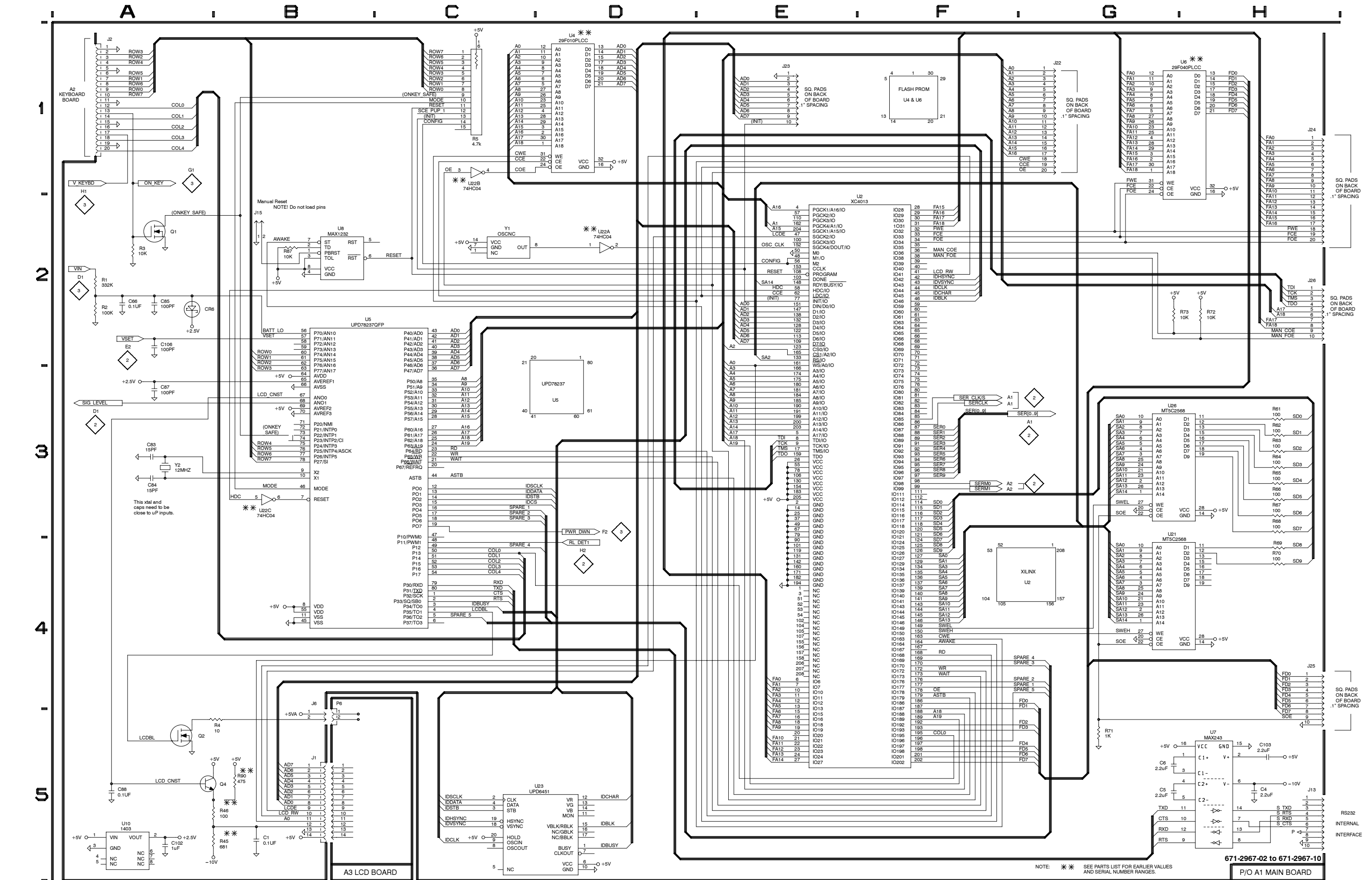

NOTE: ** SEE PARTS LIST FOR EARLIER VALUES AND SERIAL NUMBER RANGES.

671-2967-02 to 671-2967-10

P/O A1 MAIN BOARD

**A1 Main Board and Schematic Diagram <1> Component Locator Chart
(671-2967-00)**

(With cross-references to schematic diagrams 1, 2, and 3.)

A1 Main Board. Partial assembly A1 also shown on schematics 2 and 3

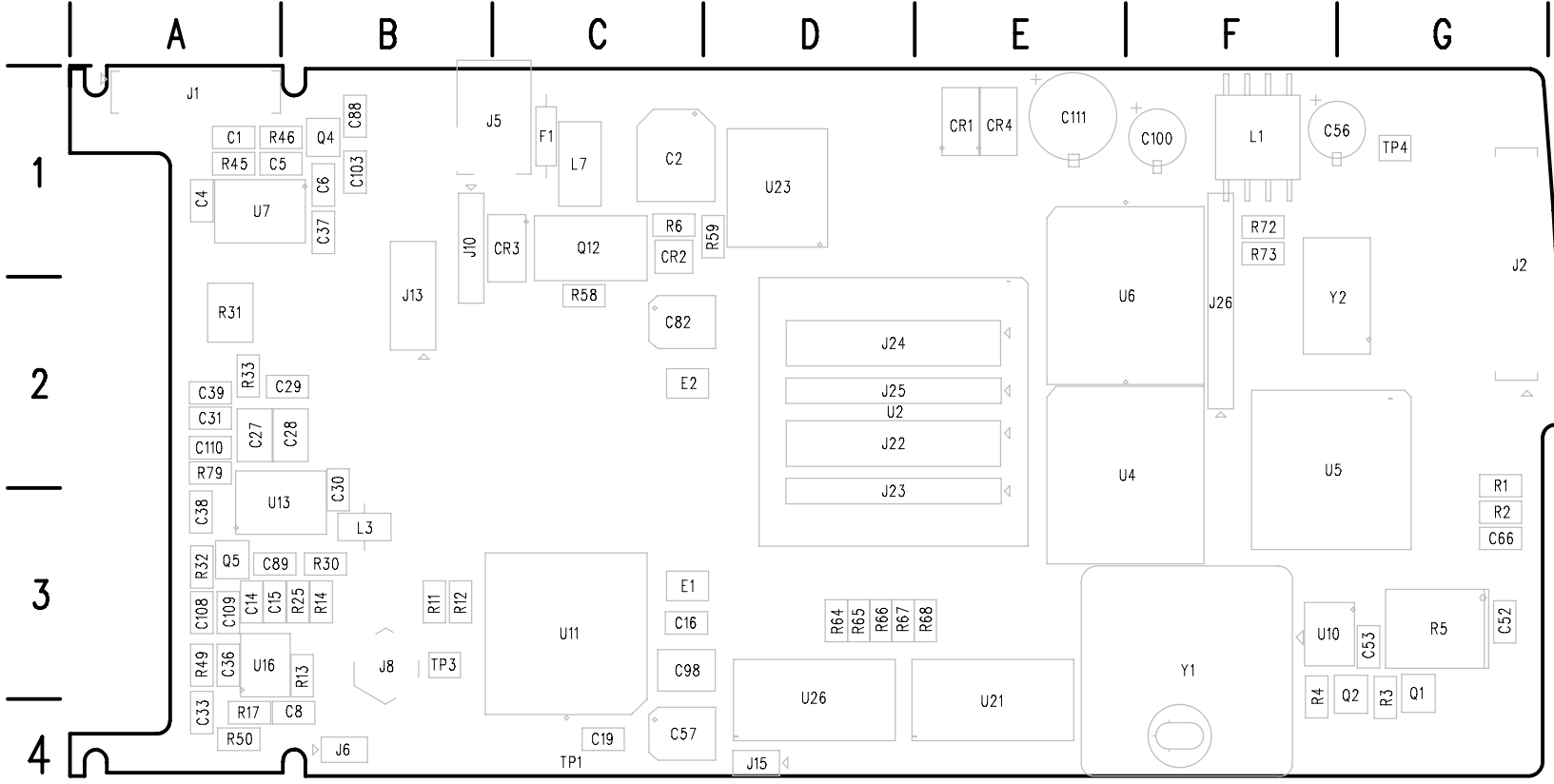

A1 Main Board (front) 671-2967-00

Static Sensitive Devices
See Maintenance Section

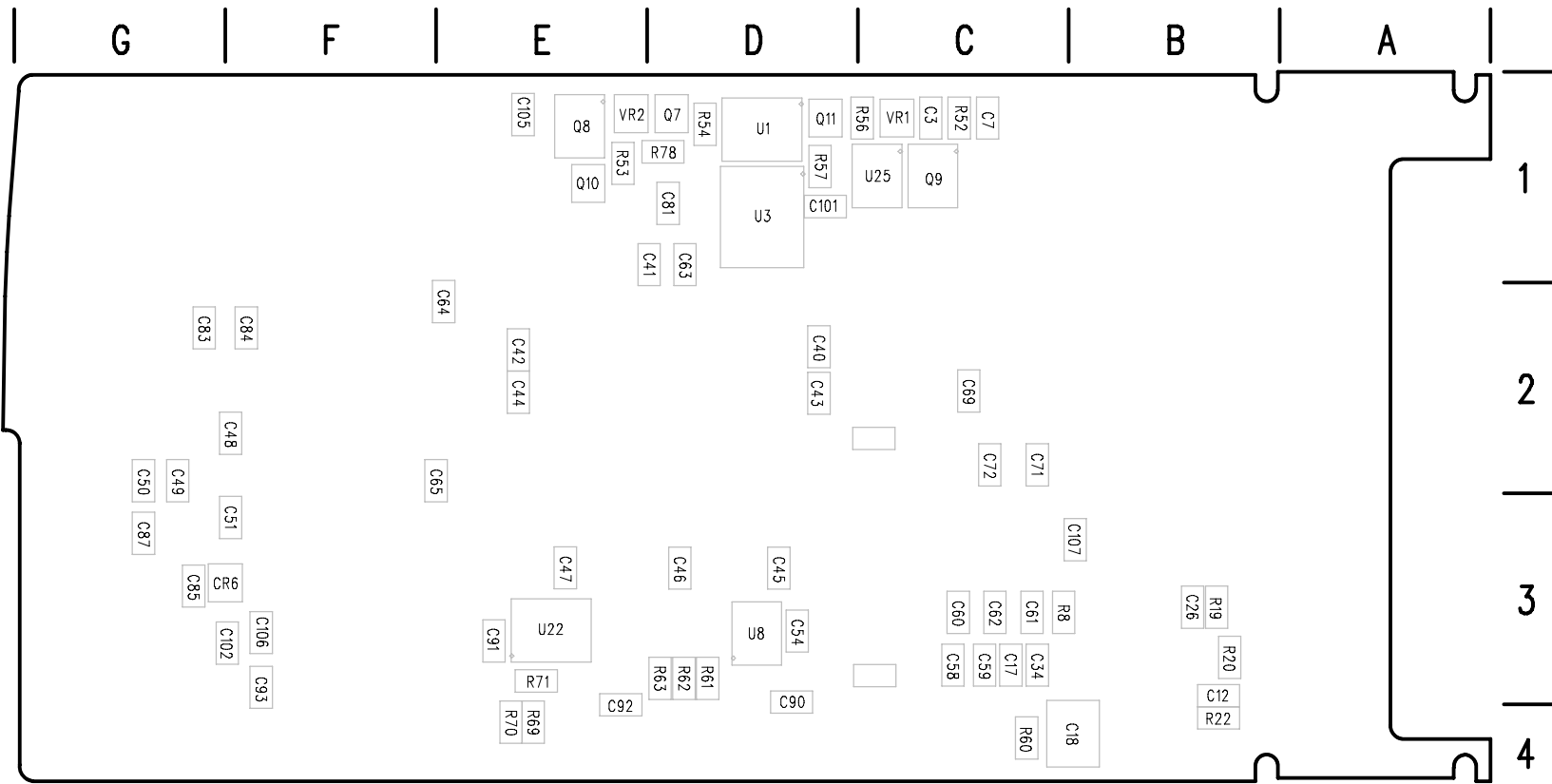

A1 Main Board (back) 671-2967-00

Comp No	Diag No	Diag Loc	Bd Loc	Comp No	Diag No	Diag Loc	Bd Loc	Comp No	Diag No	Diag Loc	Bd Loc	Comp No	Diag No	Diag Loc	Bd Loc
C1	1	B5	A1	C63 †	3	G3	D1	J15	1	B2	D4	R56 †	3	G1	C1
C2	3	D1	C1	C64 †	3	H3	E2	J22	1	G1	D2				
C3 †	3	D1	C1	C65 †	3	H3	E2	J23	1	E1	D3	R57 †	3	F2	D1
C4	1	H5	A1	C66 †	1	A2	G3	J24	1	H1	D2	R58	3	B2	C2
C5	1	G5	A1	C68 †	3	G3	C2	J25	1	H4	D2	R59	3	B2	D1
C6	1	G5	B1	C69 †	3	G3	C2	J26	1	H2	F2	R60 †	2	A2	C4
C7 †	3	C1	C1	C71 †	3	H3	C2					R61 †	1	H3	D3
								L1A	3	F2	F1	R62 †	1	H3	D3
C8	2	E1	B4	C72 †	3	H3	C2	L1B	3	F3	F1	R63 †	1	H3	D3
C12 †	2	F1	B3	C81 †	3	H3	D1	L3	2	G2	B3				
C14	2	E1	A3	C82	3	G3	C2	L7	3	B1	C1	R64	1	H3	D3
C15	2	F1	A3	C83 †	1	A3	G2					R65	1	H3	D3
C16	2	A1	C3	C84 †	1	A3	F2	P6	1	B5		R66	1	H3	D3
C17 †	2	A2	C3	C85 †	1	A2	G3					R67	1	H3	D3
C18 †	2	A2	B4	C87 †	1	A3	G3	Q1	1	A2	G3	R68	1	H3	E3
								Q2	1	A5	G4	R69 †	1	H4	E4
C19	2	B2	C4	C88	1	A5	B1	Q4	1	A5	B1	R70 †	1	H4	E4
C26 †	2	F2	B3	C89	2	D1	A3	Q5	2	D1	A3				
C27	2	H2	A2	C90 †	3	G3	D4	Q7 †	3	D					

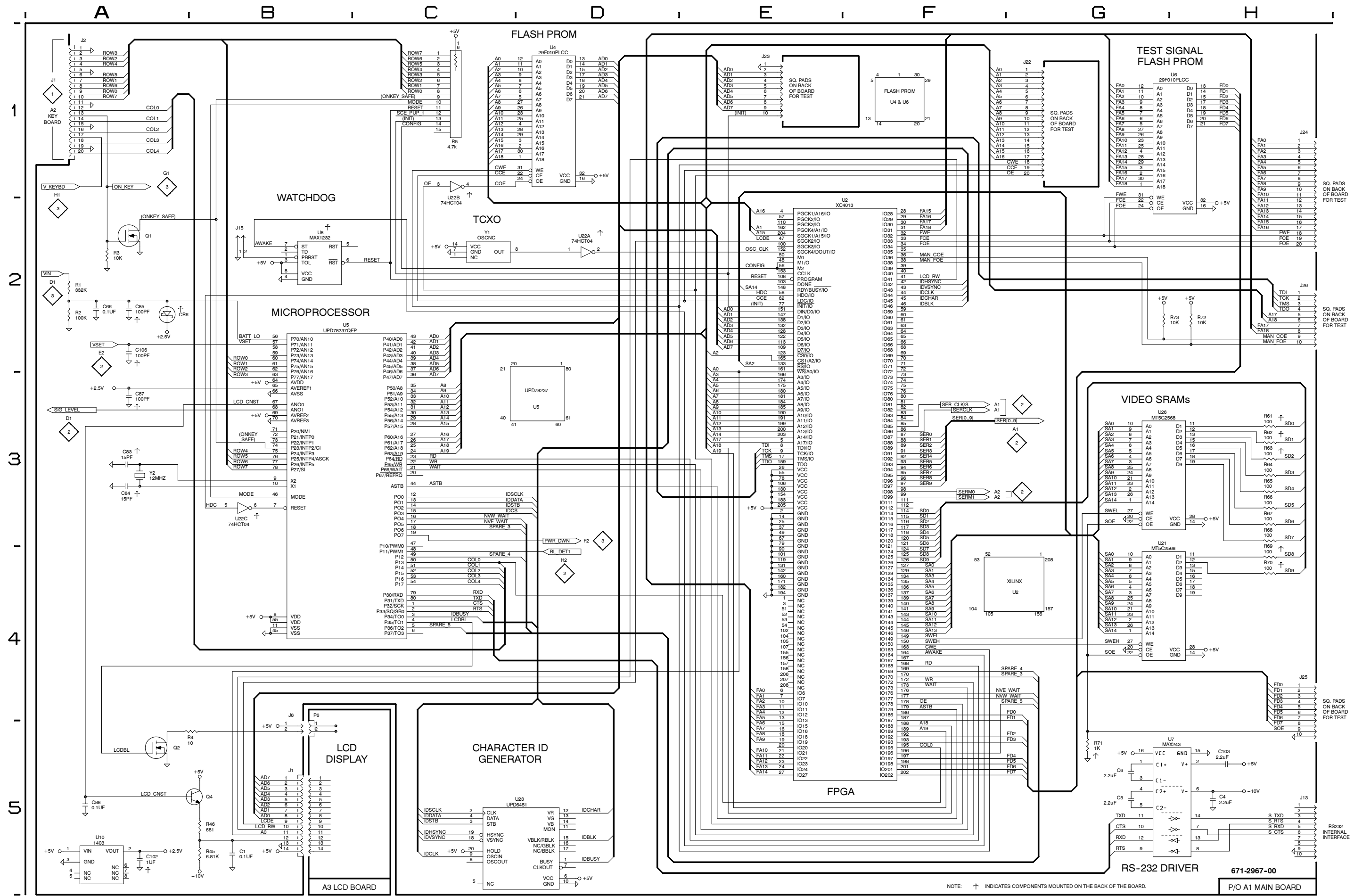

NOTE: † INDICATES COMPONENTS MOUNTED ON THE BACK OF THE BOARD.

**A1 Schematic Diagram <2>
Component Locator Chart
(671-2967-11 and Above)**

A1 Main Board. Partial assembly A1 also shown on schematic diagrams 1 and 3.

Comp No	Diag Loc	Bd Loc	Comp No	Diag Loc	Bd Loc	Comp No	Diag Loc	Bd Loc
C8	C4	B4	J8	C8	B3	R22	C5	B4
C9	C3	C4				R25	C5	B3
C12	C5	B3	L3	D5	B3	R30	D5	B3
C14	C4	A3				R31	D8	A2
C15	C5	A3	Q5	D4	A3	R32	D4	A3
C26	D5	B3	R7	C2	C3	R33	D7	A2
C27	D7	A2	R8	C2	C3	R49	D4	A3
C28	D5	B2	R9	D2	C3	R50	D4	A4
C29	D5	A2	R10	D2	C3	R79	D6	A2
C30	D6	B3	R11	C3	B3	R85	C1	
C31	D6	A2	R12	C3	B3	RT1	D7	B2
C33	D4	A4	R13	D4	B3			
C89	D4	A3	R14	D5	B3	TP1	B2	C4
C108	C4	A3	R17	C4	A4			
C109	C4	A3	R19	C5	B3	U11	C2	C3
C110	D6	A2	R20	C5	B3	U13	D6	A3
						U16	C3	A3

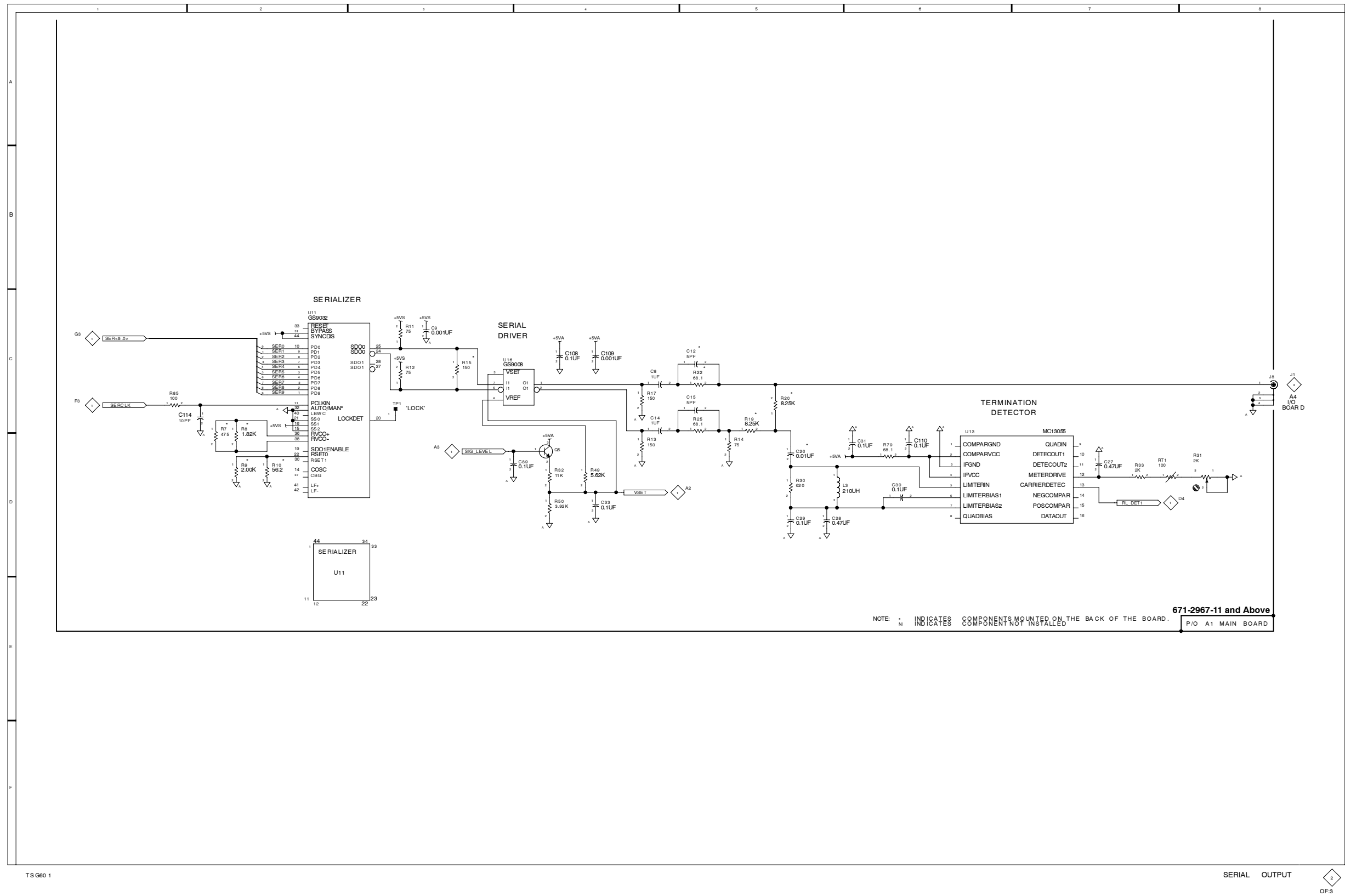

**A1 Schematic Diagram <2>
Component Locator Chart
(671-2967-02 to 671-2967-10)**

A1 Main Board. Partial assembly A1 also shown on schematic diagrams 1 and 3.

Comp No	Diag Loc	Bd Loc	Comp No	Diag Loc	Bd Loc	Comp No	Diag Loc	Bd Loc
C8	E1	B4	C98	B1	C3	R19	F1	B3
C12	F1	B3	C107	A1	B3	R20	F1	B3
C14	E1	A3	C108	D1	A3	R22	F1	B4
C15	F1	A3				R25	F1	B3
C16	A1	C3	C109	D1	A3			
			C110	G2	A2	R30	F2	B3
C17	A2	C3				R31	H2	A2
C18	A2	B4	J8	G1	B3	R32	E2	A3
C19	B2	C4				R33	H2	A2
C26	F2	B3	L3	G2	B3	R49	E2	A3
C27	H2	A2						
			Q5	D1	A3	R50	E2	A4
C28	G2	B2				R60	A2	C4
C29	F2	A2	R8	C1	C3	R79	G2	A2
C30	G2	B3	R11	C1	B3			
C31	G2	A2	R12	C1	B3	TP1	B2	C4
C33	E2	A4	R13	E1	B3			
			R14	F1	B3	U11	B1	C3
C34	B2	C3				U13	G2	A3
C89	D1	A3	R17	E1	A4	U16	C1	A3

A B C D E F G H

1
2
3
4
5

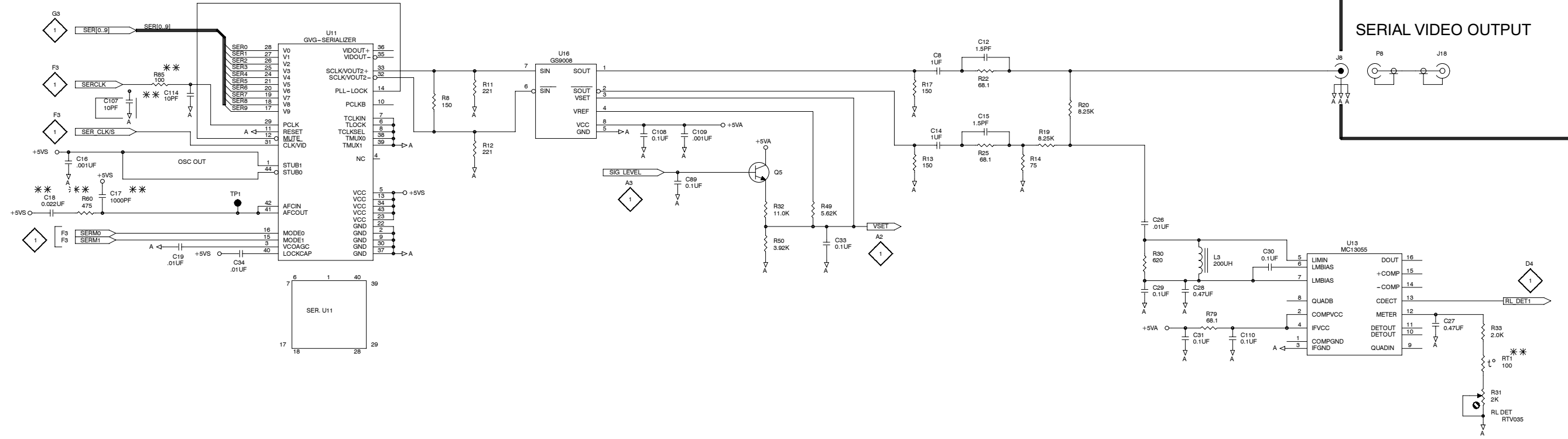

SERIAL VIDEO OUTPUT

671-2967-02 to 671-2967-10
P/O A1 MAIN BOARD

NOTE: ** SEE PARTS LIST FOR EARLIER VALUES AND SERIAL NUMBER RANGES.

**A1 Schematic Diagram <2>
Component Locator Chart
(671-2967-00)**

A1 Main Board. Partial assembly A1 also shown on schematic diagrams 1 and 3.

Comp No	Diag Loc	Bd Loc	Comp No	Diag Loc	Bd Loc	Comp No	Diag Loc	Bd Loc
C8	E1	B4	C98	B1	C3	R19	F1	B3
C12	F1	B3	C107	A1	B3	R20	F1	B3
C14	E1	A3	C108	D1	A3	R22	F1	B4
C15	F1	A3				R25	F1	B3
C16	A1	C3	C109	D1	A3			
			C110	G2	A2	R30	F2	B3
C17	A2	C3				R31	H2	A2
C18	A2	B4	J8	G1	B3	R32	E2	A3
C19	B2	C4				R33	H2	A2
C26	F2	B3	L3	G2	B3	R49	E2	A3
C27	H2	A2						
			Q5	D1	A3	R50	E2	A4
C28	G2	B2				R60	A2	C4
C29	F2	A2	R8	C1	C3	R79	G2	A2
C30	G2	B3	R11	C1	B3			
C31	G2	A2	R12	C1	B3	TP1	B2	C4
C33	E2	A4	R13	E1	B3			
			R14	F1	B3	U11	B1	C3
C34	B2	C3				U13	G2	A3
C89	D1	A3	R17	E1	A4	U16	C1	A3

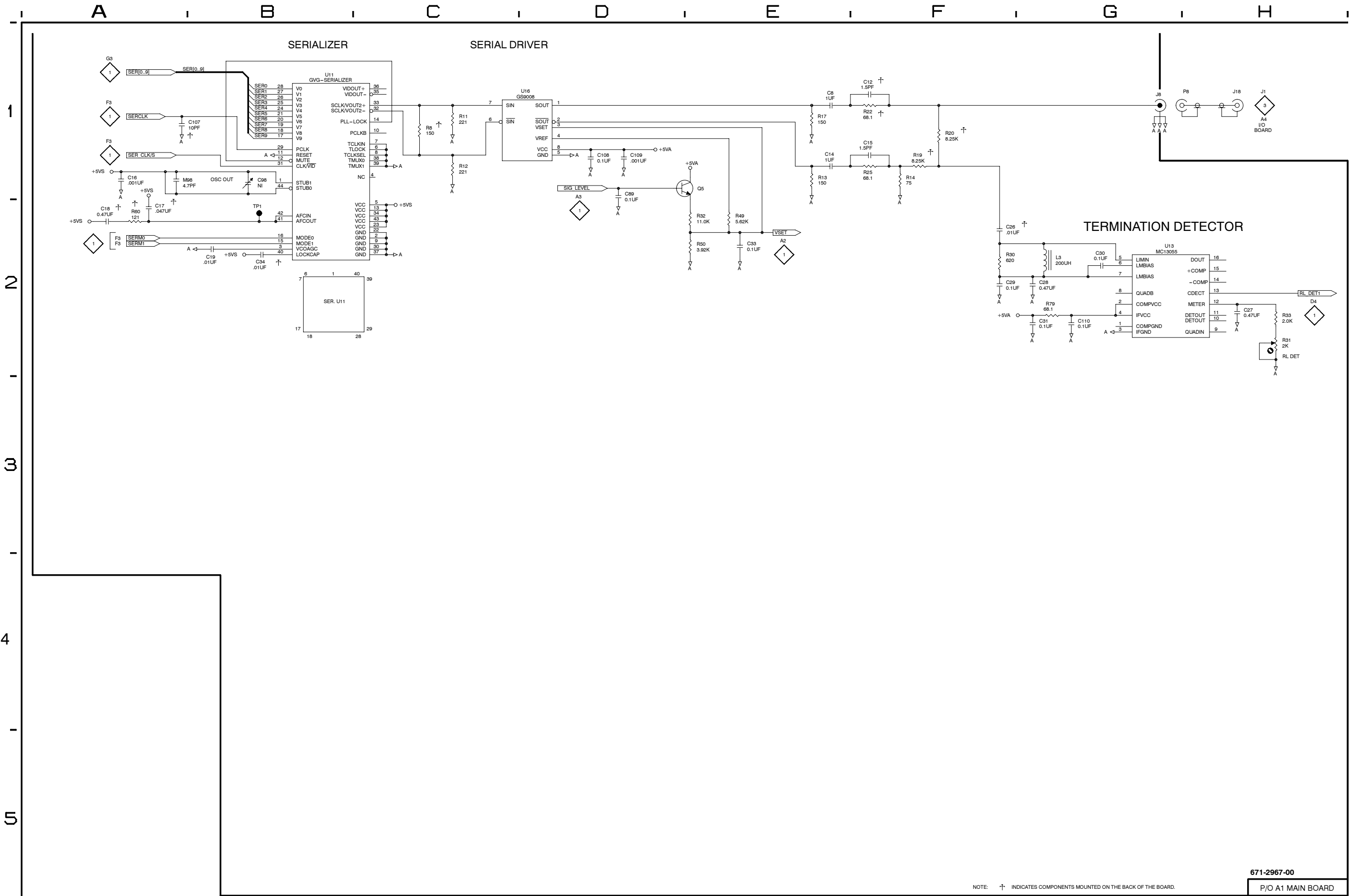

NOTE: † INDICATES COMPONENTS MOUNTED ON THE BACK OF THE BOARD.

671-2967-00
P/O A1 MAIN BOARD

**A1 Schematic Diagram <3>
Component Locator Chart
(671-2967-11 and Above)**

A1 Main Board. Partial assembly A1 also shown on schematic diagrams 1 and 2.

Comp No	Diag Loc	Bd Loc	Comp No	Diag Loc	Bd Loc	Comp No	Diag Loc	Bd Loc
C2	A3	C1	C62	D7	C3			
C3	A4	C1	C63	D7	D1	Q7	C4	D1
C7	A2	C1	C64	D7	E2	Q8	C5	E1
C36	D7	A3	C65	D7	E2	Q9	A3	C1
C37	C6	B1				Q10	C4	E1
			C81	D7	D1	Q11	B6	D1
C38	D6	A3	C90	D6	D4	Q12	B2	C1
C39	D6	A2	C91	D6	E3			
C40	C7	D2				R6	B2	C1
C41	C7	D1	C92	D7	E4	R52	B3	C1
C42	C7	E2	C93	D7	F3	R53	C4	E1
			C100	D6	F1	R54	C4	D1
C43	C7	D2	C101	A6	D1	R56	B6	C1
C44	C7	E2	C105	A3	E1			
C45	C6	D3	C111	A3	E1	R57	B6	D1
C46	C6	D3	C115	B7	D1	R58	B2	C2
C47	C7	E3				R59	B2	D1
			CR1	C5	E1	R78	C4	D1
C48	C7	F2	CR2	B2	C1			
C49	C7	G2	CR3	A1	C1	TP3	D5	B3
C50	C7	G2	CR4	C4	E1	TP4	D5	G1
C51	C7	F3				TP5	D5	B3
C52	D6	G3	E1	D6	C3	TP6	D5	G1
C53	D6	G3	F1	A2	C1	U1A	B7	D1
C54	D7	D3				U1B	A6	D1
C56	D7	F1	J5	A1	C1	U3	C3	D1
C57	D6	C4	J10	B1	B1	U25	A6	C1
C58	D7	C3						
			L1A	C5	F1	VR1	A3	C1
C59	D7	C3	L1B	D6	F1	VR2	C4	E1
C60	D7	C3	L7	A2	C1			
C61	D7	C3						

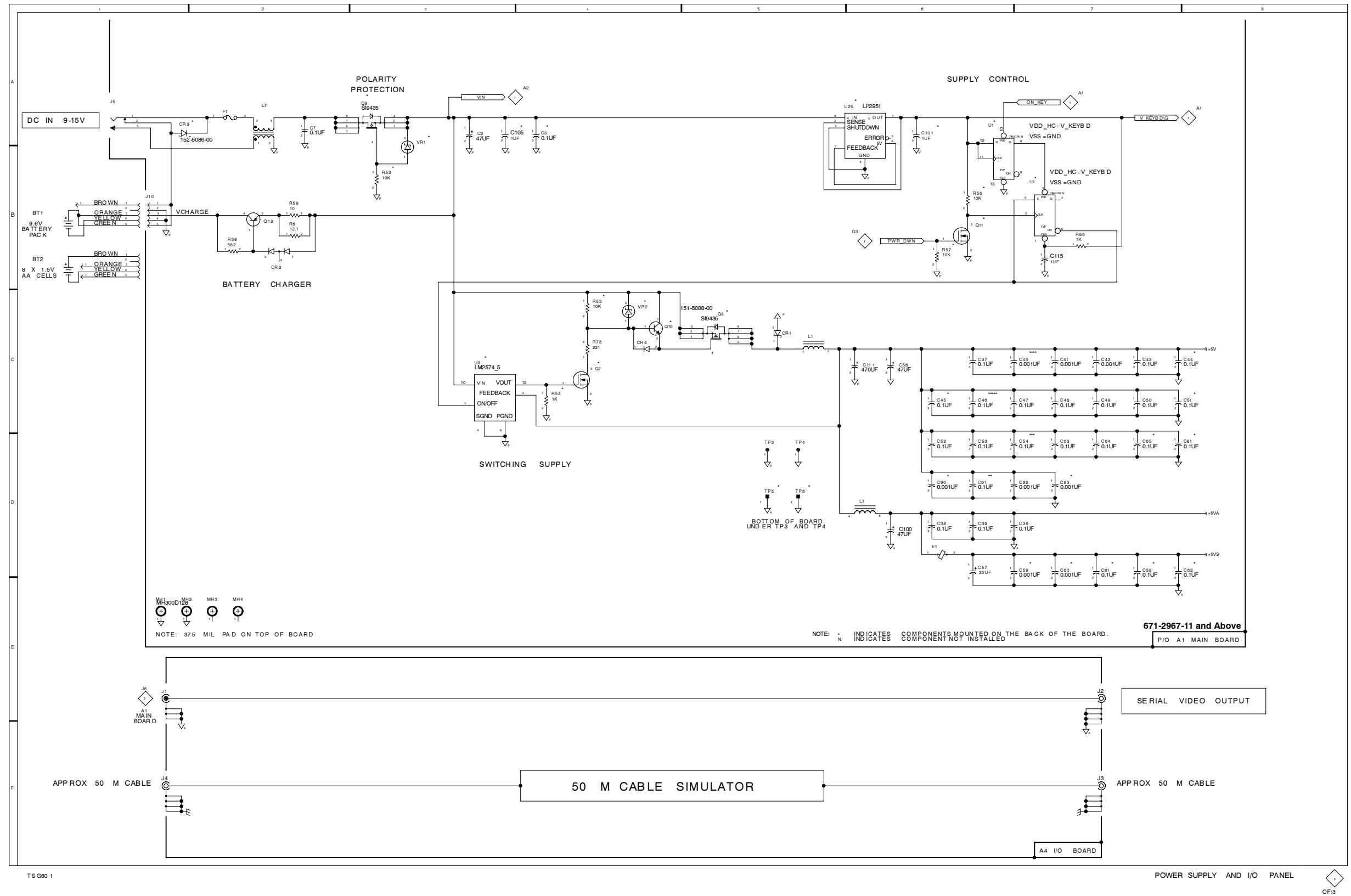

**A1 Schematic Diagram <3>
Component Locator Chart
(671-2967-02 and Above)**

A1 Main Board. Partial assembly A1 also shown on schematic diagrams 1 and 2.

Comp No	Diag Loc	Bd Loc	Comp No	Diag Loc	Bd Loc	Comp No	Diag Loc	Bd Loc
C2	D1	C1	C63	G3	D1	L1A	F2	F1
C3	D1	C1				L1B	F3	F1
C7	C1	C1	C64	H3	E2	L7	B1	C1
C36	G2	A3	C65	H3	E2			
C37	G2	B1	C68	G3	C2	Q7	D2	D1
			C69	G3	C2	Q8	E2	E1
C38	G3	A3	C71	H3	C2	Q9	C1	C1
C39	G3	A2				Q10	E2	E1
C40	G2	D2	C72	H3	C2	Q11	G1	D1
C41	G2	D1	C81	H3	D1	Q12	B2	C1
C42	H2	E2	C82	G3	C2			
			C90	G3	D4	R6	B2	C1
C43	H2	D2	C91	G3	E3	R52	C1	C1
C44	H2	E2				R53	D2	E1
C45	G3	D3	C92	G3	E4	R54	D2	D1
C46	G3	D3	C93	G3	F3	R56	G1	C1
C47	G3	E3	C100	F3	F1			
			C101	F1	D1	R57	F2	D1
C48	G3	F2	C105	D1	E1	R58	B2	C2
C49	H3	G2	C111	F2	E1	R59	B2	D1
C50	H3	G2				R78	D2	D1
C51	H3	F3	CR1	F2	E1			
C52	G3	G3	CR2	B2	C1	TP3	F3	B3
			CR3	B1	C1	TP4	F3	G1
			CR4	E2	E1			
C53	G3	G3				U1A	G1	D1
C54	G3	D3				U1B	G1	D1
C56	F2	F1	E1	G4	C3	U3	C2	D1
C57	G4	C4	E2	G3	C2	U25	F1	C1
C58	G4	C3	F1	B1	C1			
C59	G4	C3				VR1	C1	C1
C60	H4	C3	J5	A1	C1	VR2	E2	E1
C61	H4	C3	J10	A1	B1			
C62	H4	C3						

A B C D E F G H

1

2

3

4

5

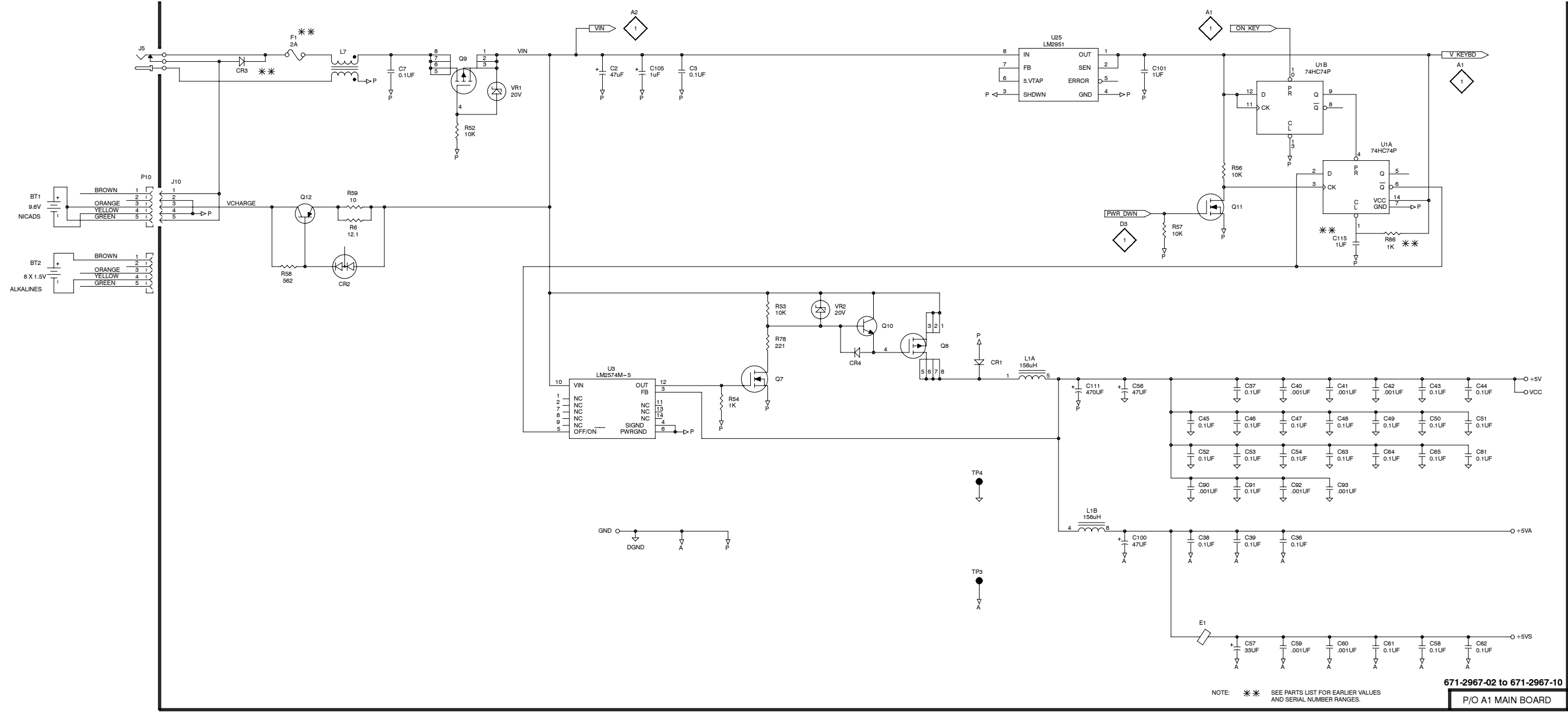

NOTE: ** SEE PARTS LIST FOR EARLIER VALUES AND SERIAL NUMBER RANGES. P/O A1 MAIN BOARD

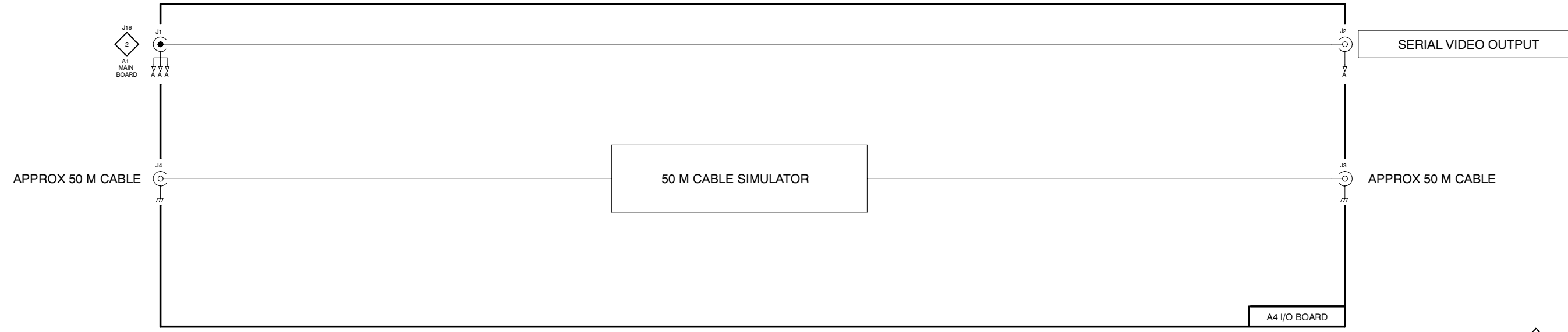

**A1 Schematic Diagram <3>
Component Locator Chart
(671-2967-00)**

A1 Main Board. Partial assembly A1 also shown on schematic diagrams 1 and 2.

Comp No	Diag Loc	Bd Loc	Comp No	Diag Loc	Bd Loc	Comp No	Diag Loc	Bd Loc
C2	D1	C1	C63	G3	D1	L1A	F2	F1
C3	D1	C1				L1B	F3	F1
C7	C1	C1	C64	H3	E2	L7	B1	C1
C36	G2	A3	C65	H3	E2			
C37	G2	B1	C68	G3	C2	Q7	D2	D1
			C69	G3	C2	Q8	E2	E1
C38	G3	A3	C71	H3	C2	Q9	C1	C1
C39	G3	A2				Q10	E2	E1
C40	G2	D2	C72	H3	C2	Q11	G1	D1
C41	G2	D1	C81	H3	D1	Q12	B2	C1
C42	H2	E2	C82	G3	C2			
			C90	G3	D4	R6	B2	C1
C43	H2	D2	C91	G3	E3	R52	C1	C1
C44	H2	E2				R53	D2	E1
C45	G3	D3	C92	G3	E4	R54	D2	D1
C46	G3	D3	C93	G3	F3	R56	G1	C1
C47	G3	E3	C100	F3	F1			
			C101	F1	D1	R57	F2	D1
C48	G3	F2	C105	D1	E1	R58	B2	C2
C49	H3	G2	C111	F2	E1	R59	B2	D1
C50	H3	G2				R78	D2	D1
C51	H3	F3	CR1	F2	E1			
C52	G3	G3	CR2	B2	C1	TP3	F3	B3
			CR3	B1	C1	TP4	F3	G1
			CR4	E2	E1			
C53	G3	G3				U1A	G1	D1
C54	G3	D3				U1B	G1	D1
C56	F2	F1	E1	G4	C3	U3	C2	D1
C57	G4	C4	E2	G3	C2	U25	F1	C1
C58	G4	C3	F1	B1	C1			
C59	G4	C3				VR1	C1	C1
C60	H4	C3	J5	A1	C1	VR2	E2	E1
C61	H4	C3	J10	A1	B1			
C62	H4	C3						

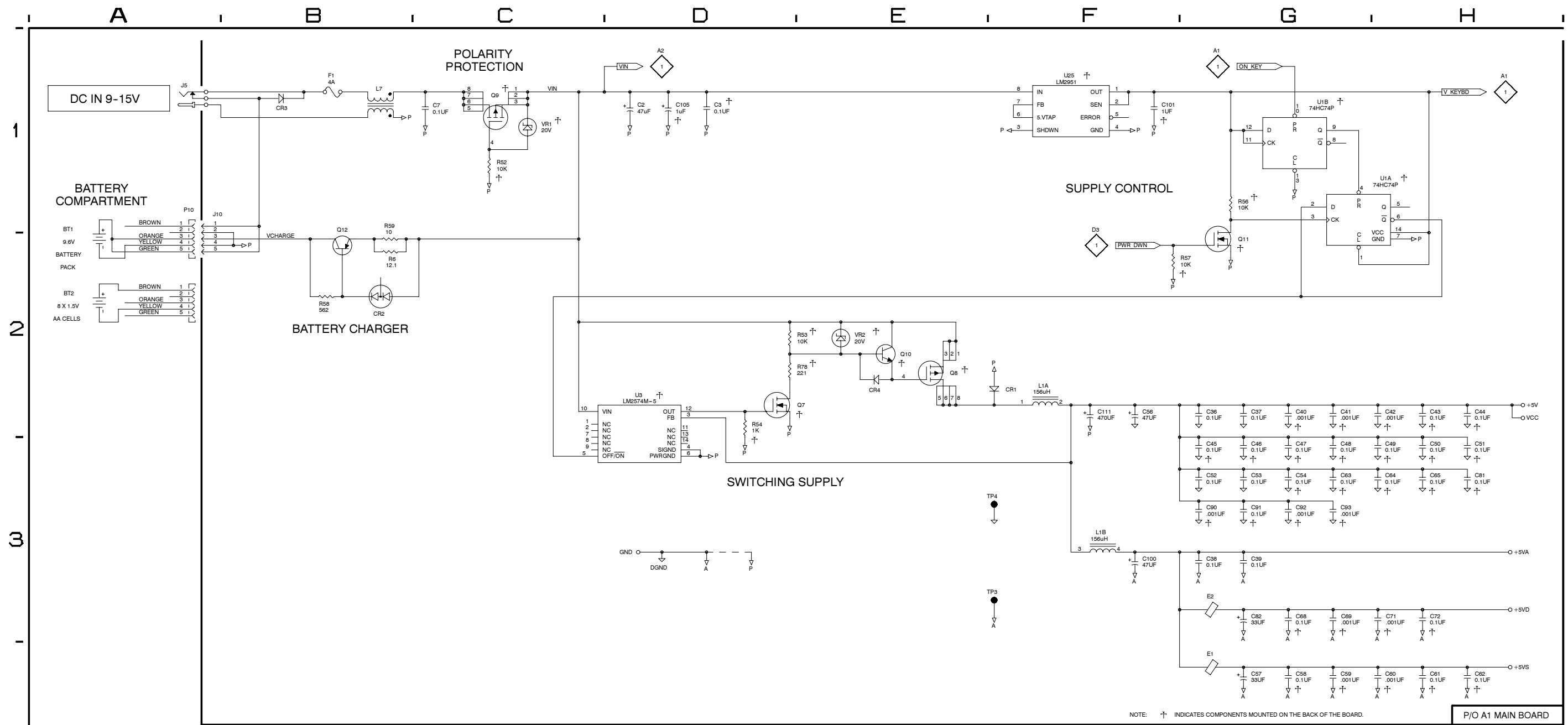

NOTE: † INDICATES COMPONENTS MOUNTED ON THE BACK OF THE BOARD.

P/O A1 MAIN BOARD

671-2967-00



Replaceable Mechanical Parts

Replaceable Mechanical Parts

This section contains a list of the components that are replaceable for the TSG 601. Use this list to identify and order replacement parts. There is a separate Replaceable Mechanical Parts list for each instrument.

Parts Ordering Information

Replacement parts are available from or through your local Tektronix, Inc., Field Office or representative.

Changes to Tektronix instruments are sometimes made to accommodate improved components as they become available and to give you the benefit of the latest circuit improvements. Therefore, when ordering parts, it is important to include the following information in your order.

- Part number
- Instrument type or model number
- Instrument serial number
- Instrument modification number, if applicable

If a part you have ordered has been replaced with a new or improved part, your local Tektronix, Inc., Field Office or representative will contact you concerning any change in part number.

Change information, if any, is located at the rear of this manual.

Using the Replaceable Mechanical Parts List

The tabular information in the Replaceable Mechanical Parts list is arranged for quick retrieval. Understanding the structure and features of the list will help you find all of the information you need for ordering replaceable parts.

Abbreviations Abbreviations conform to American National Standards Institute (ANSI) standard Y1.1.

Chassis Parts Chassis-mounted parts and cable assemblies are located at the end of the Replaceable Electrical Parts list.

Column Descriptions

**Figure & Index No.
(Column 1)** Items in this section are referenced by figure and index numbers to the illustrations.

**Tektronix Part No.
(Column 2)** Indicates part number to be used when ordering replacement part from Tektronix.

**Serial No.
(Column 3 and 4)** Column three (3) indicates the serial number at which the part was first used. Column four (4) indicates the serial number at which the part was removed. No serial number entered indicates part is good for all serial numbers.

Qty (Column 5) This indicates the quantity of mechanical parts used.

**Name and Description
(Column 6)**

An item name is separated from the description by a colon (:). Because of space limitations, an item name may sometimes appear as incomplete. Use the U.S. Federal Catalog handbook H6-1 for further item name identification.

Following is an example of the indentation system used to indicate relationship.

1	2	3	4	5	Name & Description
					Assembly and/or Component
					Mounting parts for Assembly and/or Component
					MOUNTING PARTS/*END MOUNTING PARTS*
					Detail Part of Assembly and/or Component
					Mounting parts for Detail Part
					MOUNTING PARTS/*END MOUNTING PARTS*
					Parts of Detail Part
					Mounting parts for Parts of Detail Part
					MOUNTING PARTS/*END MOUNTING PARTS*

Mounting Parts always appear in the same indentation as the Item it mounts, while the detail parts are indented to the right. Indented items are part of and included with, the next higher indentation. **Mounting parts must be purchased separately, unless otherwise specified.**

Replaceable Mechanical Parts

Fig. & Index No.	Tektronix Part No.	Serial Number Effective	Dscont	Qty	12345	Name & Description
1-1	614-0913-00		B041584	1		KIT ASSEMBLY:BATTERY HOLDER SUB ASSEMBLY
	614-0913-01	B041585	B049999	1		KIT ASSEMBLY:BATTERY HOLDER SUB ASSEMBLY
	614-0913-02	B050000		1		KIT ASSEMBLY:BATTERY HOLDER SUB ASSEMBLY *MOUNTING PARTS*
-2	211-0097-00			4		SCREW,MACHINE:4-40 X 0.312,PNH,STL *END MOUNTING PARTS*
-3	348-1347-00			4		PAD,CUSHIONING:TSG90
-4	200-4075-00			1		DOOR,BATTERY:POLYCARBONATE
-5	333-4145-00		B049999	1		REAR,PANEL:PLASTIC,TSG601
	333-4145-01	B050000		1		REAR,PANEL:PLASTIC,TSG601
-6	-----			1		CKT BD ASSY:REAR PANEL BOARD (SEE A4 REPL) *MOUNTING PARTS*
-7	211-0661-00			3		SCR,ASSEM WSHR:4-40 X 0.25,PNH,STL,CD PL,POZ,MACH
-8	214-4661-00			1		SPRING,EMI CNTC:SPRING,EMI CONTACT,0.004 CU-BE, HEAT TREAT TO HARD,0.0003 INCH MIN TINMATE,TSG601 *END MOUNTING PARTS*
-9	-----			1		CIRCUIT BOARD:MAIN (SEE A1 REPL)
-10	426-2408-00			1		SPACER,ECB:ABS,BLACK,TSG601
-11	-----			1		CIRCUIT BD ASSY:KEYBOARD (SEE A2 REPL)
-12	119-4709-00			1		KEYPAD:TSG601
-13	361-1636-00			2		SPACER:SANTOPREN
-14	-----			1		DISPLAY,MODULE:,LCD;16 CHARACTERS X 2 LINES,5 X 7 DOT MATRIX,TRANSFLECTIVE,YEL/GRN LEDBACKLIGHT,WIDE TEMP RANGE (SEE A3 REPL)
-15	614-0920-00			1		KIT ASSEMBLY:378-2073-00,202-0230-03
						STANDARD ACCESSORIES
	016-1229-00			1		CASE,CARRYING:TSG90
	070-8909-00			1		MANUAL,TECH:INSTRUCTION,CARD,TSG601
-16	119-7284-00			1		POWER SUPPLY; WALL MOUNT;12W, 120VAC 60HZ IN, 12VDC 1.0A OUT, UNREG, USA;183CM CABLE, RT ANG CONN, W/NOISE, FILTER;
-18	See Description			1		POWER CORD, ONE OF:
						OPTION COUNTRY P/N
					A0	N. AMERICA 161-0066-00
					A1	UNIV EURO 161-0066-09
					A2	UK 161-0066-10
					A3	AUSTRALIA 161-0066-13
					A6	JAPAN 161-0298-00
					A10	CHINA 161-0304-00
					A99	NO POWER CORD
						OPTIONAL ACCESSORIES
-17	119-4488-02			1		BAT PACK ASSY:
	070-8910-xx			1		MANUAL,TECH:USER,TSG601
	070-8911-xx			1		MANUAL,TECH:SERVICE,TSG601,DP
	386-6787-01			1		FLIP STAND

FIG. 1 EXPLODED VIEW

